



**Thermo Fisher Scientific**

# **CLINIConic™ 30x15**

**Instruction Manual**

50121050-3

October 2009

© 2009 Thermo Fisher Scientific Inc. All rights reserved.

AutoLock™ and CLINIConic™ are either registered trademarks or trademarks of Thermo Fisher Scientific.

All other trademarks are the property of Thermo Fisher Scientific Inc. and its subsidiaries.

Thermo Fisher Scientific Inc. provides this document to its customers with a product purchase to use in the product operation. This document is copyright protected and any reproduction of the whole or any part of this document is strictly prohibited, except with the written authorization of Thermo Fisher Scientific Inc.

The contents of this document are subject to change without notice. All technical information in this document is for reference purposes only. System configurations and specifications in this document supersede all previous information received by the purchaser.

**Thermo Fisher Scientific Inc. makes no representations that this document is complete, accurate or error-free and assumes no responsibility and will not be liable for any errors, omissions, damage or loss that might result from any use of this document, even if the information in the document is followed properly.**

This document is not part of any sales contract between Thermo Fisher Scientific Inc. and a purchaser. This document shall in no way govern or modify any Terms and Conditions of Sale, which Terms and Conditions of Sale shall govern all conflicting information between the two documents.

Release history: 50121050-3 printed in October 2009.

**For Research Use Only. Not for use in diagnostic procedures.**

# Table of Contents

<b>Preface</b> .....	<b>iii</b>
<b>Scope of Supply</b> .....	<b>iii</b>
<b>Precautions</b> .....	<b>iii</b>
<b>Chapter 1 Rotor Specifications</b> .....	<b>1-1</b>
Heraeus .....	1-2
Heraeus 230V 50Hz/60Hz ventilated .....	1-2
Heraeus 230V 50Hz/60Hz refrigerated .....	1-2
Heraeus 120V 60Hz ventilated .....	1-3
Heraeus 120V 60Hz refrigerated .....	1-3
Sorvall .....	1-4
Sorvall 230V 50Hz/60Hz ventilated .....	1-4
Sorvall 230V 50Hz/60Hz refrigerated .....	1-4
Sorvall 120V 60Hz ventilated .....	1-5
Sorvall 120V 60Hz refrigerated .....	1-5
Sorvall 100V 50/60Hz ventilated .....	1-6
Sorvall 100V 50/60Hz refrigerated .....	1-6
Thermo Scientific .....	1-7
Thermo Scientific 230V 50Hz/60Hz ventilated .....	1-7
Thermo Scientific 230V 50Hz/60Hz refrigerated .....	1-7
Thermo Scientific 120V 60Hz ventilated .....	1-8
Thermo Scientific 120V 60Hz refrigerated .....	1-8
<b>Chapter 2 Accessories</b> .....	<b>2-1</b>
<b>Chapter 3 AutoLock™</b> .....	<b>3-1</b>
Rotor Installation .....	3-2
Removing the Rotor .....	3-3
<b>Chapter 4 Rotor Loading</b> .....	<b>4-1</b>
Before a Run .....	4-2
Proper Loading .....	4-2
Improper Loading .....	4-2
Maximum Loading .....	4-3
Cycle Counter .....	4-4
<b>Chapter 5 Maintenance and Care</b> .....	<b>5-1</b>
Cleaning Intervals .....	5-2
Cleaning .....	5-2
Disinfection .....	5-3
Decontamination .....	5-4

## Contents

Autoclaving .....	5-5
Service of Thermo Fisher Scientific .....	5-5
<b>RCF-Values .....</b>	<b>A-1</b>
<b>Chemical Compatibility Chart .....</b>	<b>B-1</b>
<b>Contact Information .....</b>	<b>C-1</b>

## Preface

Before starting to use the rotor, read through these instruction manual carefully and follow the instructions.

The information contained in these instruction manual is the property of Thermo Fisher Scientific; it is forbidden to copy or pass on this information without explicit approval.

Failure to follow the instructions and safety information in this instruction manual will result in the expiration of the seller's warranty.

## Scope of Supply

Article Number		Quantity	Check
75003623	CLINIConic™ 30x15	1	<input type="checkbox"/>
50121050	Instruction Manual	1	<input type="checkbox"/>

If any parts are missing, please contact the nearest Thermo Fisher Scientific representative.

## Precautions

In order to ensure safe operation of the CLINIConic™ 30x15, the following general safety regulations must be followed:

- Do not remove the magnet at the rotor bottom
- Do not use rotors which show any signs of corrosion and/or cracks.
- Use only with rotors that have been loaded properly.
- Never run the rotor with missing stainless steel tube holders.
- Never overload the rotor.
- Use only accessories which have been approved by Thermo Fisher Scientific. Exceptions to this rule are commercially available glass or plastic centrifuge tubes, provided they have been approved for the speed or the RCF value of the rotor.

## Preface

- Please observe the safety instructions.

Please pay particular attention to the following aspects:

- Rotor installation: Check that the rotor is locked properly into place before operating the centrifuge.
- Always balance the samples.

Maximum sample density at maximum speed:  $1,2 \frac{g}{ml}$



This symbol refers to general hazards.

ATTENTION means that material damage could occur.

WARNING means that injuries or material damage or contamination could occur.



This symbol refers to biological hazards.

Observe the information contained in the instruction manual to keep yourself and your environment safe.

# Rotor Specifications

## Contents

- “Heraeus” on page 1-2
- “Sorvall” on page 1-4
- “Thermo Scientific” on page 1-7

# Heraeus

**Table 1-1.** Heraeus 230V 50Hz/60Hz ventilated

Centrifuge	Heraeus Multifuge X1	Heraeus Megafuge 16
Catalog #	75004210	75004230
Weight empty [kg] of rotor	4.7	4.7
max. cycle number	50,000	50,000
Maximum permissible load [g]	30x30	30x30
maximum speed $n_{max}$ [rpm]	5,650	5,650
maximum RCF value at $n_{max}$	4,997	4,997
max. / min. radius [cm]	14.0 / 8.5	14.0 / 8.5
Pitch angle [°]	37	37
Accel. / braking time [s]	30 / 35	30 / 35
sample heating at $n_{max}$ [° C] referred to ambient temperature of 23 °C, running time 60 minutes	9	9
aerosol-tight	no	no
permissible temperature range autoclavable °C	121	121

**Table 1-2.** Heraeus 230V 50Hz/60Hz refrigerated

Centrifuge	Heraeus Multifuge X1 R	Heraeus Megafuge 16R
Catalog #	75004250	75004270
Weight empty [kg] of rotor	4.7	4.7
max. cycle number	50,000	50,000
Maximum permissible load [g]	30x30	30x30
maximum speed $n_{max}$ [rpm]	5,650	5,650
maximum RCF value at $n_{max}$	4,997	4,997
max. / min. radius [cm]	14.0 / 8.5	14.0 / 8.5
Pitch angle [°]	37	37
Accel. / braking time [s]	30 / 35	30 / 35
aerosol-tight	no	no
permissible temperature range autoclavable °C	121	121



**Table 1-3.** Heraeus 120V 60Hz ventilated

<b>Centrifuge</b>	<b>Heraeus Multifuge X1</b>	<b>Heraeus Megafuge 16</b>
Catalog #	75004211	75004231
Weight empty [kg] of rotor	4.7	4.7
max. cycle number	50,000	50,000
Maximum permissible load [g]	30x30	30x30
maximum speed $n_{max}$ [rpm]	5,650	5,650
maximum RCF value at $n_{max}$	4,997	4,997
max. / min. radius [cm]	14.0 / 8.5	14.0 / 8.5
Pitch angle [°]	37	37
Accel. / braking time [s]	40 / 40	40 / 40
sample heating at $n_{max}$ [° C] referred to ambient temperature of 23 °C, running time 60 minutes	9	9
aerosol-tight	no	no
permissible temperature range autoclavable °C	121	121

**Table 1-4.** Heraeus 120V 60Hz refrigerated

<b>Centrifuge</b>	<b>Heraeus Multifuge X1 R</b>	<b>Heraeus Megafuge 16R</b>
Catalog #	75004251	75004271
Weight empty [kg] of rotor	4.7	4.7
max. cycle number	50,000	50,000
Maximum permissible load [g]	30x30	30x30
maximum speed $n_{max}$ [rpm]	5,650	5,650
maximum RCF value at $n_{max}$	4,997	4,997
max. / min. radius [cm]	14.0 / 8.5	14.0 / 8.5
Pitch angle [°]	37	37
Accel. / braking time [s]	40 / 40	40 / 40
aerosol-tight	no	no
permissible temperature range autoclavable °C	121	121

# Sorvall

**Table 1-5.** Sorvall 230V 50Hz/60Hz ventilated

Centrifuge	Sorvall Legend X1	Sorvall ST 16
Catalog #	75004220	75004240
Weight empty [kg] of rotor	4.7	4.7
max. cycle number	50,000	50,000
Maximum permissible load [g]	30x30	30x30
maximum speed $n_{max}$ [rpm]	5,650	5,650
maximum RCF value at $n_{max}$	4,997	4,997
max. / min. radius [cm]	14.0 / 8.5	14.0 / 8.5
Pitch angle [°]	37	37
Accel. / braking time [s]	30 / 35	30 / 35
sample heating at $n_{max}$ [° C] referred to ambient temperature of 23 °C, running time 60 minutes	9	9
aerosol-tight	no	no
permissible temperature range autoclavable °C	121	121

**Table 1-6.** Sorvall 230V 50Hz/60Hz refrigerated

Centrifuge	Sorvall Legend X1R	Sorvall ST 16R
Catalog #	75004260	75004380
Weight empty [kg] of rotor	4.7	4.7
max. cycle number	50,000	50,000
Maximum permissible load [g]	30x30	30x30
maximum speed $n_{max}$ [rpm]	5,650	5,650
maximum RCF value at $n_{max}$	4,997	4,997
max. / min. radius [cm]	14.0 / 8.5	14.0 / 8.5
Pitch angle [°]	37	37
Accel. / braking time [s]	30 / 35	30 / 35
aerosol-tight	no	no
permissible temperature range autoclavable °C	121	121

**Table 1-7.** Sorvall 120V 60Hz ventilated

<b>Centrifuge</b>	<b>Sorvall Legend X1</b>	<b>Sorvall ST 16</b>
Catalog #	75004221	75004241
Weight empty [kg] of rotor	4.7	4.7
max. cycle number	50,000	50,000
Maximum permissible load [g]	30x30	30x30
maximum speed $n_{max}$ [rpm]	5,650	5,650
maximum RCF value at $n_{max}$	4,997	4,997
max. / min. radius [cm]	14.0 / 8.5	14.0 / 8.5
Pitch angle [°]	37	37
Accel. / braking time [s]	40 / 40	40 / 40
sample heating at $n_{max}$ [° C] referred to ambient temperature of 23 °C, running time 60 minutes	9	9
aerosol-tight	no	no
permissible temperature range autoclavable °C	121	121

**Table 1-8.** Sorvall 120V 60Hz refrigerated

<b>Centrifuge</b>	<b>Sorvall Legend X1R</b>	<b>Sorvall ST 16R</b>
Catalog #	75004261	75004381
Weight empty [kg] of rotor	4.7	4.7
max. cycle number	50,000	50,000
Maximum permissible load [g]	30x30	30x30
maximum speed $n_{max}$ [rpm]	5,650	5,650
maximum RCF value at $n_{max}$	4,997	4,997
max. / min. radius [cm]	14.0 / 8.5	14.0 / 8.5
Pitch angle [°]	37	37
Accel. / braking time [s]	40 / 40	40 / 40
aerosol-tight	no	no
permissible temperature range autoclavable °C	121	121

## 1 Rotor Specifications

Sorvall

**Table 1-9.** Sorvall 100V 50/60Hz ventilated

Centrifuge	Sorvall Legend 1X	Sorvall ST 16
Catalog #	75004223	75004243
Weight empty [kg] of rotor	4.7	4.7
max. cycle number	50,000	50,000
Maximum permissible load [g]	30x30	30x30
maximum speed $n_{max}$ [rpm]	5,650	5,650
maximum RCF value at $n_{max}$	4,997	4,997
max. / min. radius [cm]	14.0 / 8.5	14.0 / 8.5
Pitch angle [°]	37	37
Accel. / braking time [s]	45/ 40	45/ 40
sample heating at $n_{max}$ [° C] referred to ambient temperature of 23 °C, running time 60 minutes	9	9
aerosol-tight	no	no
permissible temperature range autoclavable °C	121	121

**Table 1-10.** Sorvall 100V 50/60Hz refrigerated

Centrifuge	Sorvall Legend X1R	Sorvall ST 16R
Catalog #	75004263	75004383
Weight empty [kg] of rotor	4.7	4.7
max. cycle number	50,000	50,000
Maximum permissible load [g]	30x30	30x30
maximum speed $n_{max}$ [rpm]	5,650	5,650
maximum RCF value at $n_{max}$	4,997	4,997
max. / min. radius [cm]	14.0 / 8.5	14.0 / 8.5
Pitch angle [°]	37	37
Accel. / braking time [s]	45 / 40	45 / 40
aerosol-tight	no	no
permissible temperature range autoclavable °C	121	121

# Thermo Scientific

**Table 1-11.** Thermo Scientific 230V 50Hz/60Hz ventilated

Centrifuge	Thermo Scientific SL 16
Catalog #	75004000
Weight empty [kg] of rotor	4.7
max. cycle number	50,000
Maximum permissible load [g]	30x30
maximum speed $n_{max}$ [rpm]	5,650
maximum RCF value at $n_{max}$	4,997
max. / min. radius [cm]	14.0 / 8.5
Pitch angle [°]	37
Accel. / braking time [s]	30 / 35
sample heating at $n_{max}$ [° C] referred to ambient temperature of 23 °C, running time 60 minutes	9
aerosol-tight	no
permissible temperature range autoclavable °C	121

**Table 1-12.** Thermo Scientific 230V 50Hz/60Hz refrigerated

Centrifuge	Thermo Scientific SL 16R
Catalog #	75004030
Weight empty [kg] of rotor	4.7
max. cycle number	50,000
Maximum permissible load [g]	30x30
maximum speed $n_{max}$ [rpm]	5,650
maximum RCF value at $n_{max}$	4,997
max. / min. radius [cm]	14.0 / 8.5
Pitch angle [°]	37
Accel. / braking time [s]	30 / 35
aerosol-tight	no
permissible temperature range autoclavable °C	121

## 1 Rotor Specifications

Thermo Scientific

**Table 1-13.** Thermo Scientific 120V 60Hz ventilated

Centrifuge	Thermo Scientific SL 16
Catalog #	75004001
Weight empty [kg] of rotor	4.7
max. cycle number	50,000
Maximum permissible load [g]	30x30
maximum speed $n_{max}$ [rpm]	5,650
maximum RCF value at $n_{max}$	4,997
max. / min. radius [cm]	14.0 / 8.5
Pitch angle [°]	37
Accel. / braking time [s]	40 / 40
sample heating at $n_{max}$ [° C] referred to ambient temperature of 23 °C, running time 60 minutes	9
aerosol-tight	no
permissible temperature range autoclavable °C	121

**Table 1-14.** Thermo Scientific 120V 60Hz refrigerated

Centrifuge	Thermo Scientific SL 16R
Catalog #	75004031
Weight empty [kg] of rotor	4.7
max. cycle number	50,000
Maximum permissible load [g]	30x30
maximum speed $n_{max}$ [rpm]	5,650
maximum RCF value at $n_{max}$	4,997
max. / min. radius [cm]	14.0 / 8.5
Pitch angle [°]	37
Accel. / braking time [s]	40 / 40
aerosol-tight	no
permissible temperature range autoclavable °C	121

# Accessories

## Contents

- „Rotor data“ on page 2-1
- „Accessories“ on page 2-1

## CliniConic Fixed Angle Aluminum Rotor

Rotor Specifications		
Capacity (ml)	30 x 15 ml	
Tube Dimensions (mm)	16,5 x 131	
Angle °	37	
Maximum Speed (rpm)	5.650	
K Factor	3954	
Net Weight (kg)	4,7	
* Max Speed may vary depending on centrifuge unit.		
RCF/Radius	RCF (x g)	Radius (cm)
Maximum	4.997	14
Minimum	3.030	8,5



Cliniconic Fixed Angle Rotor	
Cat. No.	Description
75003623	CliniConic Fixed Angle Rotor

Tube Ordering Information													
Cat. No.	Tube Vol. (ml)	Vol. Fill (ml)	Description	Qty.	Max. Speed (rpm)	Dims ØxL (mm)	Sealing Assembly Required:			Adapters Required:		Accessories Required:	
							Cat. No.	Qty /Pkg	Description	Cat. No.	Qty /Pkg	No. of Places	
-	15	15	15ml Round / Conical	-	-	16,5 x 131	-	-	-	-	-	-	
-	10	-	Blood Collection	-	-	16,5 x 95	-	-	-	75003702	1	1	-
-	7	-	Blood Collection	-	-	16,5 x 131	-	-	-	11172595	1	1	-
-	5	-	Blood Collection	-	-	13 x 95	-	-	-	11172595	1	1	-



# AutoLock™

## Contents

- “Rotor Installation” on page 3-2
- “Removing the Rotor” on page 3-3

## Rotor Installation



### CAUTION

Unapproved or incorrectly combined accessories can cause serious damage to the centrifuge.

This rotor is equipped with an AutoLock™-system.

This system is used to automatically lock the rotor to the motor shaft. The rotor does not have to be bolted onto the motor shaft.

Proceed as follows:

1. Open the lid of the centrifuge and if necessary remove any dust, foreign objects or residue from the chamber.  
AutoLock™ and o-ring must be clean and undamaged.

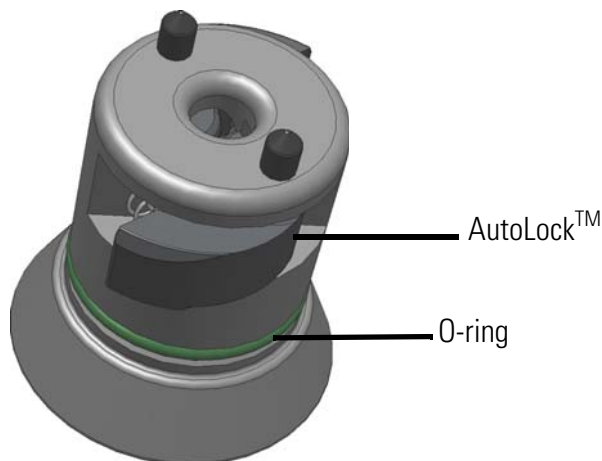

**Figure 1.** AutoLock™

2. Hold the rotor over the shaft and let it slide slowly down the shaft.  
The rotor clicks automatically into place.



### CAUTION

Do not force the rotor onto the motor shaft.

If the rotor is very light, then it may be necessary to press it onto the shaft with a small amount of pressure.

3. Check if the rotor is properly installed by lifting it slightly on the handle. If the rotor can be pulled up, then it must be reclamped to the shaft.



### WARNING

If the rotor cannot be properly locked in place after several attempts, then the AutoLock™ is defective and you are not permitted to operate the rotor.

Check for any damage to the rotor: Damaged rotors must not be used!

Keep the hub area clear of objects.



**CAUTION**

Check that the rotor is properly locked on the shaft before each use by pulling it a its handle.



Be sure to check all seals before starting any aerosol-tight applications.  
See the information in the rotor instruction manual.

4. Close the centrifuge lid.

## Removing the Rotor

To remove the rotor, proceed as follows:

1. Open the centrifuge lid.
2. Grab the rotor handle with both hands and press against the green AutoLock™ key. At the same time, pull the rotor directly upwards with both hands and remove it from the motor shaft. Make sure not to jam the rotor while doing this.

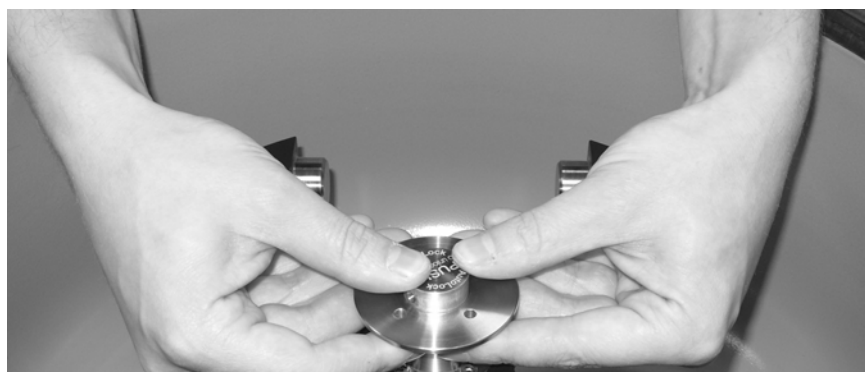

# Rotor Loading

## Contents

- “Before a run” on page 4-2
- “Proper Loading” on page 4-2
- “Improper Loading” on page 4-2
- “Maximum loading” on page 4-3
- “Cycle Counter” on page 4-4

## Before a Run

1. Please read and observe the safety instructions contained in these operating instructions and in the instructions for use.
2. Check the rotor and all accessory parts for damages such as cracks, scratches or traces of corrosion.
3. Check the rotor chamber, the motor shaft and the AutoLock™.
4. Check the rotor's suitability using the “[Chemical Compatibility Chart](#)” on [page B-1](#).
5. Make sure the tubes or bottles do not touch the lid.

## Proper Loading

To ensure safe operation of the centrifuge, the rotor must be evenly loaded at all times.

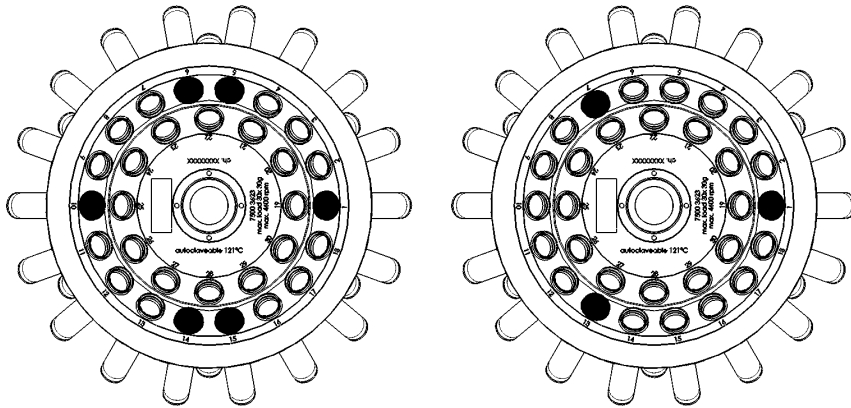

All places must contain stainless steel tube holders. Running the rotor with missing stainless steel tube holders is forbidden. Start loading the rotor on the outer ring. If you only centrifuge one sample place a test tube with water in the opposite position to balance the load.

## Improper Loading

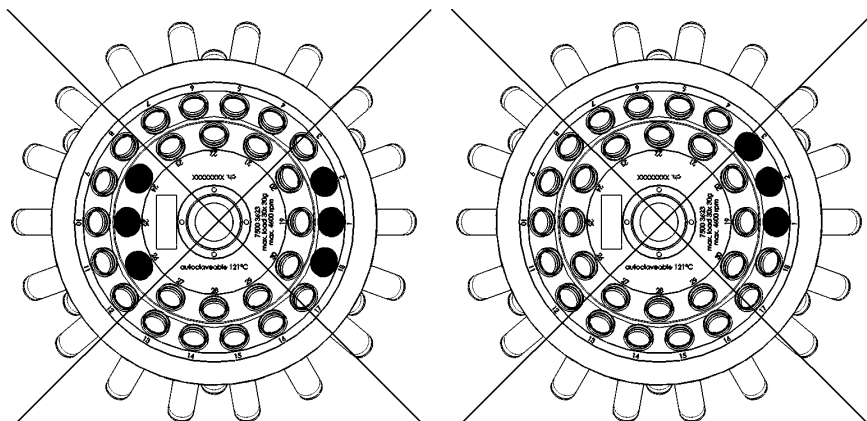

## Maximum Loading

The rotor can run at high speeds. The rotor design has sufficient reserve stability even when spinning at top speed.

The safety system of the centrifuge requires that you do not overload the rotor.

There are two options available for centrifuging samples whose weight, including adaptor, exceeds the maximum permissible load:

- Reduce the fill level.
- Reduce the speed.

Use the table or formula below.

Actual Load (g)	RPM <sub>max</sub>
30	5,650
50	4376
70	3699
90	3262
110	2951
130	2714
150	2527
170	2373

Recalculate the maximum permissible speed according to the following formula and select the calculated maximum speed for the centrifuge:

$$n_{\text{adm}} = n_{\text{max}} \sqrt{\frac{\text{Maximum permissible load}}{\text{Effective load}}}$$

$n_{\text{adm}}$  = admissible speed

$n_{\text{max}}$  = maximum speed

## Cycle Counter

The lifetime of rotors is dependent on the amount of mechanical load. Do not exceed the number of cycles recommended for rotors and buckets.

The maximum number of cycles is given in “Rotor Specifications” on page 1-1.



**WARNING** Replace the rotor when the specified number of cycles is reached. Due to the mechanical load a rotor can break and thus damage the centrifuge.

### Service life examples

Usage profile	Maximum service life at 50,000 cycles
frequent use 30 runs / day 220 days / year	7 years

# Maintenance and Care

## Contents

- “Cleaning Intervals” on page 5-2
- “Cleaning” on page 5-2
- “Disinfection” on page 5-3
- “Decontamination” on page 5-4
- “Autoclaving” on page 5-5
- “Service of Thermo Fisher Scientific” on page 5-5



## Cleaning Intervals

For the sake of personal, environmental, and material protection, it is your duty to clean and if necessary disinfect the centrifuge on a regular basis.

Maintenance	Recommended interval
Clean rotor chamber	daily or when polluted
Clean rotor	daily or when polluted
Accessories	daily or when polluted
Cabinet	Once per month
Ventilation holes	Every six months



**CAUTION** Refrain from using any other cleaning or decontamination procedure than those recommended here, if you are not entirely sure that the intended procedure is safe for the equipment.

Use only approved cleansers.

If in doubt, contact Thermo Fisher Scientific.

## Cleaning

When cleaning centrifug

- Use warm water with a neutral solvent.
- Never use caustic cleaning agents such as soap suds, phosphoric acid, bleaching solutions or scrubbing powder.
- Rinse the cavities out thoroughly.
- Use a soft brush without metal bristles to remove stubborn residue.
- Afterwards rinse with distilled water.
- Place the rotors on a plastic grate with their cavities pointing down.
- If drying boxes are used, the temperature must never exceed 50 °C, since higher temperatures could damage the material and shorten the lifetime of the parts.
- Use only disinfectants with a pH of 6-8.
- Dry aluminum parts off with a soft cloth.
- After cleaning, treat the entire surface of aluminum parts with corrosion protection oil (7000 9824). Also treat the cavities with oil.
- Store the aluminum parts at room temperature or in a cold-storage room with the cavities pointing down.



**CAUTION** Before using any cleaning or decontamination methods except those recommended by the manufacturer, users should check with the manufacturer that the proposed method will not damage the equipment.

Clean centrifuge and accessories as follows:

1. Open the centrifuge.
2. Turn off the centrifuge.
3. Pull out the power supply plug.
4. Grasp the rotor with both hands and lift it vertically off the centrifuge spindle.
5. Remove the centrifuge tubes and adaptors.
6. Use a neutral cleaning agent with a pH value between 6 and 8 for cleaning.
7. Dry all of the rotors and accessories after cleaning with a cloth or in a warm air cabinet at a maximum temperature of 50°C.
8. Clean the housing of the centrifuge as needed.
  - After cleaning, treat the entire surface of aluminum parts with corrosion protection oil (7000 9824). Also treat the cavities with oil.
  - Treat the bold of the swing out rotor with bold grease (75003786).



**CAUTION** When cleaning, do not allow liquids, especially organic solvents, to get on the drive shaft, the bearings, the AutoLock™ or the locks. Organic solvents break down the grease in the motor bearing. The drive shaft could freeze up.

After some applications there might be ice in the rotor chamber. Let the ice melt and drain it off. Clean the rotor chamber as described above.

## Disinfection

Disinfect the centrifuge immediately whenever infectious material has spilled during centrifugation.



**WARNING** Infectious material can get into the centrifuge when a tube breaks or as a result of spills. Keep in mind the risk of infection when touching the rotor and take all necessary precautions. In case of contamination, make sure that others are not put at risk. Decontaminate the affected parts immediately. Take other precautions if needed.

Use a sprayer whenever possible so that all surfaces are covered evenly.

The rotor chamber and the rotor should be treated preferably with a neutral disinfectant. A disinfectant spray would be most suitable for this purpose so that the rotor and accessory surfaces are covered evenly.



**CAUTION** Before using any cleaning or decontamination methods except those recommended by the manufacturer, users should check with the manufacturer that the proposed method will not damage the equipment. Observe the safety precautions and handling instructions for the cleaning agents used.

Contact the Service Department of Thermo Fisher Scientific for questions regarding the use of other disinfectants.

Disinfect the rotor and accessories as follows:

1. Open the centrifuge.
  2. Turn off the centrifuge.
  3. Pull out the power supply plug.
  4. Grasp the rotor with both hands and lift it vertically off the centrifuge spindle.
  5. Remove the centrifuge tubes and adaptors and dispose of them or disinfect them.
  6. Treat the rotor and accessories according to the instructions for the disinfectant (spray or soak in solution). Adhere strictly to the given application times.
  7. Be sure the disinfectant can drain off the rotor.
  8. Rinse the rotor and rotor lid thoroughly with water and then rub down.
  9. Dispose of the disinfectant according to the applicable guidelines.
  10. Dry all of the rotors and accessories after cleaning with a cloth or in a warm air cabinet at a maximum temperature of 50°C.
- After cleaning, treat the entire surface of aluminum parts with corrosion protection oil (7000 9824). Also treat the cavities with oil.
  - Treat the rotor with rotor grease (75003786).

## Decontamination

Decantamine the centrifuge immediately whenever radioactive material has spilled during centrifugation.



**WARNING** Radioactive material can get into the centrifuge when a tube breaks or as a result of spills. Keep in mind the risk of infection when touching the rotor and take all necessary precautions.

In case of contamination, make sure that others are not put at risk.

Decontaminate the affected parts immediately.

Take other precautions if need be.



**CAUTION** Before using any cleaning or decontamination methods except those recommended by the manufacturer, users should check with the manufacturer that the proposed method will not damage the equipment.

For general radioactive decontamination use a solution of equal parts of 70% ethanol, 10% SDS and water.

Disinfect the rotor and accessories as follows:

1. Open the centrifuge.
2. Turn off the centrifuge.
3. Pull out the power supply plug.
4. Grasp the rotor with both hands and lift it vertically off the centrifuge spindle.

5. Remove the centrifuge tubes and adaptors and dispose of them or disinfect them.
6. Rinse the rotor first with ethanol and then with de-ionized water.
  - Adhere strictly to the given application times.
7. Be sure the decontamination solution can drain off the rotor.
8. Rinse the rotor and accessories thoroughly with water.
9. Dispose of the decontamination solution according to the applicable guidelines.
10. Dry all of the rotors and accessories after cleaning with a cloth or in a warm air cabinet at a maximum temperature of 50°C.
  - After cleaning, treat the entire surface of aluminum parts with corrosion protection oil (7000 9824). Also treat the cavities with oil.
  - Treat the body of the swing out rotor with body grease (75003786).

## Autoclaving

1. Before autoclaving clean rotor and accessories as described above.
2. Place the rotor on a flat surface.
  - Rotors and adapter can be autoclaved at 121 °C.
  - The maximum permissible autoclave cycle is 20 minutes at 121 °C.

Clean the rotor before autoclaving and rinse it with distilled water. Remove all accessories (tubes, adapters) from the rotor. Place the rotor on a flat surface.

**Note** No chemical additives are permitted in the steam.



**CAUTION** Never exceed the permitted temperature and duration when autoclaving. If the rotor shows signs of corrosion or wear, it must be replaced.

## Service of Thermo Fisher Scientific

Thermo Fisher Scientific recommends having the centrifuge and accessories serviced once a year by an authorized service technician. The service technicians check the following:

- the electrical equipment
- the suitability of the set-up site
- the lid lock and the safety system
- the rotor
- the fixation of the rotor and the drive shaft

Thermo Fisher Scientific offers inspection and service contracts for this work.

## RCF-Values

Speed (rpm)	R <sub>min</sub>	R <sub>max</sub>	RCF R <sub>min</sub>	RCF R <sub>max</sub>
300	8.5	14.0	9	14
400	8.5	14.0	15	25
500	8.5	14.0	24	39
600	8.5	14.0	34	56
700	8.5	14.0	47	77
800	8.5	14.0	61	100
900	8.5	14.0	77	127
1000	8.5	14.0	95	157
1100	8.5	14.0	115	189
1200	8.5	14.0	137	225
1300	8.5	14.0	161	265
1400	8.5	14.0	186	307
1500	8.5	14.0	214	352
1600	8.5	14.0	243	401
1700	8.5	14.0	275	452
1800	8.5	14.0	308	507
1900	8.5	14.0	343	565
2000	8.5	14.0	380	626
2100	8.5	14.0	419	690
2200	8.5	14.0	460	758
2300	8.5	14.0	503	828
2400	8.5	14.0	547	902
2500	8.5	14.0	594	978
2600	8.5	14.0	642	1058
2700	8.5	14.0	693	1141
2800	8.5	14.0	745	1227
2900	8.5	14.0	799	1316
3000	8.5	14.0	855	1409

Speed (rpm)	R <sub>min</sub>	R <sub>max</sub>	RCF R <sub>min</sub>	RCF R <sub>max</sub>
3100	8.5	14.0	913	1504
3200	8.5	14.0	973	1603
3300	8.5	14.0	1035	1705
3400	8.5	14.0	1099	1809
3500	8.5	14.0	1164	1917
3600	8.5	14.0	1232	2028
3700	8.5	14.0	1301	2143
3800	8.5	14.0	1372	2260
3900	8.5	14.0	1445	2381
4000	8.5	14.0	1520	2504
4100	8.5	14.0	1597	2631
4200	8.5	14.0	1676	2761
4300	8.5	14.0	1757	2894
4400	8.5	14.0	1840	3030
4500	8.5	14.0	1924	3170
4600	8.5	14.0	2011	3312
4700	8.5	14.0	2099	3458
4800	8.5	14.0	2189	3606
4900	8.5	14.0	2282	3758
5000	8.5	14.0	2376	3913
5100	8.5	14.0	2472	4071
5200	8.5	14.0	2570	4232
5300	8.5	14.0	2669	4397
5400	8.5	14.0	2771	4564
5500	8.5	14.0	2875	4735
5600	8.5	14.0	2980	4908
5,650	8.5	14.0	3034	4,997

# Chemical Compatibility Chart

CHEMICAL	ALUMINUM	ANODIC COATING for ALUMINUM	BUNA N	CELLULOSE ACETATE BUTYRATE	POLYURETHANE ROTOR PAINT	COMPOSITE Carbon Fiber/Epoxy	DELFIN®	ETHYLENE PROPYLENE	GLASS	NEOPRENE	NORYL®	NYLON	PET®, POLYCLEAR®, CLEARCRIMP®, CCLEARCRIMP®	POLYALLOMER	POLYCARBONATE	POLYESTER, GLASS THERMOSET	POLYETHERIMIDE	POLYRTHYLENE	POLYPROPYLENE	POLYSULFONE	POLYVINYL CHLORIDE	RULON A®, TEFLON®	SILICONE RUBBER	STAINLESS STEEL	TITANIUM	TYGON®	VITON®
2-mercaptoethanol	S	S	U	-	S	M	S	-	S	U	S	S	U	S	S	-	S	S	S	S	U	S	S	S	S	S	S
Acetaldehyde	S	-	U	U	-	-	-	M	-	U	-	-	-	M	U	U	U	M	M	-	M	S	U	-	S	-	U
Acetone	M	S	U	U	S	U	M	S	S	U	U	S	U	S	U	U	U	S	S	U	U	S	M	M	S	U	U
Acetonitrile	S	S	U	-	S	M	S	-	S	S	U	S	U	M	U	U	-	S	M	U	U	S	S	S	S	U	U
Alconox®	U	U	S	-	S	S	S	-	S	S	S	S	S	S	M	S	S	S	S	S	S	S	S	S	S	S	U
Allyl Alcohol	-	-	-	U	-	-	S	-	-	-	-	S	-	S	S	M	S	S	S	S	-	M	S	-	-	S	-
Aluminum Chloride	U	U	S	S	S	S	U	S	S	S	S	M	S	S	S	S	-	S	S	S	S	S	M	U	U	S	S
Formic Acid (100%)	-	S	M	U	-	-	U	-	-	-	-	U	-	S	M	U	U	S	S	-	U	S	-	U	S	-	U
Ammonium Acetate	S	S	U	-	S	S	S	-	S	S	S	S	S	S	S	U	-	S	S	S	S	S	S	S	S	S	S
Ammonium Carbonate	M	S	U	S	S	S	S	S	S	S	S	S	S	S	U	U	-	S	S	S	S	S	S	M	S	S	S
Ammonium Hydroxide (10%)	U	U	S	U	S	S	M	S	S	S	S	S	-	S	U	M	S	S	S	S	S	S	S	S	S	M	S
Ammonium Hydroxide (28%)	U	U	S	U	S	U	M	S	S	S	S	S	U	S	U	M	S	S	S	S	S	S	S	S	S	M	S
Ammonium Hydroxide (conc.)	U	U	U	U	S	U	M	S	-	S	-	S	U	S	U	U	S	S	S	-	M	S	S	S	S	-	U
Ammonium Phosphate	U	-	S	-	S	S	S	S	S	S	S	S	-	S	S	M	-	S	S	S	S	S	S	M	S	S	S
Ammonium Sulfate	U	M	S	-	S	S	U	S	S	S	S	S	S	S	S	S	-	S	S	S	S	S	S	U	S	S	U
Amyl Alcohol	S	-	M	U	-	-	S	S	-	M	-	S	-	M	S	S	S	S	M	-	-	-	U	-	S	-	M
Aniline	S	S	U	U	S	U	S	M	S	U	U	U	U	U	U	U	-	S	M	U	U	S	S	S	S	U	S
Sodium Hydroxide (<1%)	U	-	M	S	S	S	-	-	S	M	S	S	-	S	M	M	S	S	S	S	S	S	M	S	S	-	U
Sodium Hydroxide (10%)	U	-	M	U	-	-	U	-	M	M	S	S	U	S	U	U	S	S	S	S	S	S	M	S	S	-	U
Barium Salts	M	U	S	-	S	S	S	S	S	S	S	S	S	S	S	M	-	S	S	S	S	S	S	M	S	S	S
Benzene	S	S	U	U	S	U	M	U	S	U	U	S	U	U	U	M	U	M	U	U	U	S	U	U	S	U	S
Benzyl Alcohol	S	-	U	U	-	-	M	M	-	M	-	S	U	U	U	U	U	U	U	-	M	S	M	-	S	-	S
Boric Acid	U	S	S	M	S	S	U	S	S	S	S	S	S	S	S	S	U	S	S	S	S	S	S	S	S	S	S

## B Chemical Compatibility Chart

CHEMICAL	MATERIAL																											
	ALUMINUM	ANODIC COATING for ALUMINUM	BUNA N	CELLULOSE ACETATE BUTYRATE	POLYURETHANE ROTOR PAINT	COMPOSITE Carbon Fiber/Epoxy	DELRIN®	ETHYLENE PROPYLENE	GLASS	NEOPRENE	NORYL®	NYLON	PET®, POLYCLEAR®, CLEARCRIMP®, CCCLEARCRIMP®	POLYALLOMER	POLYCARBONATE	POLYESTER, GLASS THERMOSET	POLYETHERIMIDE	POLYRTHYLENE	POLYPROPYLENE	POLYSULFONE	POLYVINYL CHLORIDE	RULON A®, TEFLON®	SILICONE RUBBER	STAINLESS STEEL	TITANIUM	TYGON®	VITON®	
Cesium Acetate	M	-	S	-	S	S	S	-	S	S	S	S	-	S	S	-	-	S	S	S	S	S	S	M	S	S	S	
Cesium Bromide	M	S	S	-	S	S	S	-	S	S	S	S	S	S	S	-	-	S	S	S	S	S	S	M	S	S	S	
Cesium Chloride	M	S	S	U	S	S	S	-	S	S	S	S	S	S	S	-	-	S	S	S	S	S	S	M	S	S	S	
Cesium Formate	M	S	S	-	S	S	S	-	S	S	S	S	S	S	S	-	-	S	S	S	S	S	S	M	S	S	S	
Cesium Iodide	M	S	S	-	S	S	S	-	S	S	S	S	S	S	S	-	-	S	S	S	S	S	S	M	S	S	S	
Cesium Sulfate	M	S	S	-	S	S	S	-	S	S	S	S	S	S	S	-	-	S	S	S	S	S	S	M	S	S	S	
Chloroform	U	U	U	U	S	S	M	U	S	U	U	M	U	M	U	U	U	M	M	U	U	S	U	U	U	M	S	
Chromic Acid (10%)	U	-	U	U	S	U	U	-	S	S	S	U	S	S	M	U	M	S	S	U	M	S	M	U	S	S	S	
Chromic Acid (50%)	U	-	U	U	-	U	U	-	-	-	S	U	U	S	M	U	M	S	S	U	M	S	-	U	M	-	S	
Cresol Mixture	S	S	U	-	-	-	S	-	S	U	U	U	U	U	U	-	-	U	U	-	U	S	S	S	S	U	S	
Cyclohexane	S	S	S	-	S	S	S	U	S	U	S	S	U	U	U	M	S	M	U	M	M	S	U	M	M	U	S	
Deoxycholate	S	S	S	-	S	S	S	-	S	S	S	S	S	S	S	-	-	S	S	S	S	S	S	S	S	S	S	
Distilled Water	S	S	S	S	S	S	S	S	S	S	S	S	S	S	S	S	S	S	S	S	S	S	S	S	S	S	S	
Dextran	M	S	S	S	S	S	S	-	S	S	S	S	S	S	S	S	S	S	S	S	S	S	S	M	S	S	S	
Diethyl Ether	S	S	U	U	S	S	S	U	S	U	U	S	U	U	U	U	U	U	U	U	U	S	S	S	S	M	U	
Diethyl Ketone	S	-	U	U	-	-	M	-	S	U	-	S	-	M	U	U	U	M	M	-	U	S	-	-	S	U	U	
Diethylpyrocarbonate	S	S	U	-	S	S	S	-	S	S	U	S	U	S	U	-	-	S	S	S	M	S	S	S	S	S	S	
Dimethylsulfoxide	S	S	U	U	S	S	S	-	S	U	S	S	U	S	U	U	-	S	S	U	U	S	S	S	S	U	U	
Dioxane	M	S	U	U	S	S	M	M	S	U	U	S	U	M	U	U	-	M	M	M	U	S	S	S	S	U	U	
Ferric Chloride	U	U	S	-	-	-	M	S	-	M	-	S	-	S	-	-	-	S	S	-	-	-	M	U	S	-	S	
Acetic Acid (Glacial)	S	S	U	U	S	S	U	M	S	U	S	U	U	U	U	U	M	S	U	M	U	S	U	U	S	-	U	
Acetic Acid (5%)	S	S	M	S	S	S	M	S	S	S	S	S	M	S	S	S	S	S	S	S	M	S	S	M	S	S	M	
Acetic Acid (60%)	S	S	U	U	S	S	U	-	S	M	S	U	U	M	U	S	M	S	M	S	M	S	M	U	S	M	U	
Ethyl Acetate	M	M	U	U	S	S	M	M	S	S	U	S	U	M	U	U	-	S	S	U	U	S	M	M	S	U	U	
Ethyl Alcohol (50%)	S	S	S	S	S	S	M	S	S	S	S	S	U	S	U	S	S	S	S	S	S	S	S	M	S	M	U	
Ethyl Alcohol (95%)	S	S	S	U	S	S	M	S	S	S	S	S	U	S	U	-	S	S	S	M	S	S	S	U	S	M	U	
Ethylene Dichloride	S	-	U	U	-	-	S	M	-	U	U	S	U	U	U	U	U	U	U	-	U	S	U	-	S	-	S	
Ethylene Glycol	S	S	S	S	S	S	S	S	S	S	S	S	-	S	U	S	S	S	S	S	S	S	S	M	S	M	S	
Ethylene Oxide Vapor	S	-	U	-	-	U	-	-	S	U	-	S	-	S	M	-	-	S	S	S	U	S	U	S	S	S	U	
Ficoll-Hypaque®	M	S	S	-	S	S	S	-	S	S	S	S	-	S	S	-	S	S	S	S	S	S	M	S	S	S	S	



<b>CHEMICAL</b>	<b>MATERIAL</b>	ALUMINUM	ANODIC COATING for ALUMINUM	BUNA N	CELLULOSE ACETATE BUTYRATE	POLYURETHANE ROTOR PAINT	COMPOSITE Carbon Fiber/Epoxy	DELRIN®	ETHYLENE PROPYLENE	GLASS	NEOPRENE	NORYL®	NYLON	PET®, POLYCLEAR®, CLEARCRIMP®, CCCLEARCRIMP®	POLYALLOMER	POLYCARBONATE	POLYESTER, GLASS THERMOSET	POLYETHERIMIDE	POLYRTHYLENE	POLYPROPYLENE	POLYSULFONE	POLYVINYL CHLORIDE	RULON A®, TEFLON®	SILICONE RUBBER	STAINLESS STEEL	TITANIUM	TYGON®	VITON®
Hydrofluoric Acid (10%)	U	U	U	M	-	-	U	-	-	U	U	S	-	S	M	U	S	S	S	S	S	M	S	U	U	U	-	-
Hydrofluoric Acid (50%)	U	U	U	U	-	-	U	-	-	U	U	U	U	U	S	U	U	U	S	S	M	M	S	U	U	U	-	M
Hydrochloric Acid (conc.)	U	U	U	U	-	U	U	M	-	U	M	U	U	M	U	U	U	-	S	-	U	S	U	U	U	-	-	
Formaldehyde (40%)	M	M	M	S	S	S	S	M	S	S	S	S	S	M	S	S	S	U	S	S	M	S	S	S	M	S	M	U
Glutaraldehyde	S	S	S	S	-	-	S	-	S	S	S	S	S	S	S	S	-	-	S	S	S	-	-	S	S	S	-	-
Glycerol	M	S	S	-	S	S	S	S	S	S	S	S	S	S	S	S	S	-	S	S	S	S	S	S	S	S	S	S
Guanidine Hydrochloride	U	U	S	-	S	S	S	-	S	S	S	S	S	S	S	S	-	-	S	S	S	S	S	S	U	S	S	S
Haemo-Sol®	S	S	S	-	-	-	S	-	S	S	S	S	S	S	S	S	-	-	S	S	S	S	S	S	S	S	S	S
Hexane	S	S	S	-	S	S	S	-	S	S	U	S	U	M	U	S	S	U	S	S	M	S	U	S	S	U	S	
Isobutyl Alcohol	-	-	M	U	-	-	S	S	-	U	-	S	U	S	S	M	S	S	S	S	-	S	S	S	-	S	-	S
Isopropyl Alcohol	M	M	M	U	S	S	S	S	S	U	S	S	U	S	U	M	S	S	S	S	S	S	S	S	M	M	M	S
Iodoacetic Acid	S	S	M	-	S	S	S	-	S	M	S	S	M	S	S	-	M	S	S	S	S	S	S	M	S	S	M	M
Potassium Bromide	U	S	S	-	S	S	S	-	S	S	S	S	S	S	S	S	S	S	S	S	-	S	S	S	M	S	S	S
Potassium Carbonate	M	U	S	S	S	S	S	-	S	S	S	S	S	S	U	S	S	S	S	S	S	S	S	S	S	S	S	S
Potassium Chloride	U	S	S	-	S	S	S	S	S	S	S	S	S	S	S	S	-	S	S	S	S	S	S	S	U	S	S	S
Potassium Hydroxide (5%)	U	U	S	S	S	S	M	-	S	S	S	S	-	S	U	S	S	S	S	S	S	S	S	M	U	M	S	U
Potassium Hydroxide (conc.)	U	U	M	U	-	-	M	-	M	S	S	-	U	M	U	U	U	S	M	-	M	U	-	U	U	-	U	
Potassium Permanganate	S	S	S	-	S	S	S	-	S	S	S	U	S	S	S	M	-	S	M	S	U	S	S	M	S	U	S	
Calcium Chloride	M	U	S	S	S	S	S	S	S	S	S	S	S	S	M	S	-	S	S	S	S	S	S	S	M	S	S	S
Calcium Hypochlorite	M	-	U	-	S	M	M	S	-	M	-	S	-	S	M	S	-	S	S	S	M	S	M	U	S	-	S	
Kerosene	S	S	S	-	S	S	S	U	S	M	U	S	U	M	M	S	-	M	M	M	S	S	U	S	S	U	S	
Sodium Chloride (10%)	S	-	S	S	S	S	S	S	-	-	-	S	S	S	S	S	-	S	S	S	S	-	S	S	M	-	S	
Sodium Chloride (sat'd)	U	-	S	U	S	S	S	-	-	-	-	S	S	S	S	S	-	S	S	-	S	-	S	S	M	-	S	
Carbon Tetrachloride	U	U	M	S	S	U	M	U	S	U	U	S	U	M	U	S	S	M	M	S	M	M	M	M	U	S	S	
Aqua Regia	U	-	U	U	-	-	U	-	-	-	-	-	U	U	U	U	U	U	U	U	-	-	-	-	-	S	-	M
Solution 555 (20%)	S	S	S	-	-	-	S	-	S	S	S	S	S	S	S	S	-	-	S	S	S	-	S	S	S	S	S	
Magnesium Chloride	M	S	S	-	S	S	S	S	S	S	S	S	S	S	S	S	S	S	S	S	S	S	S	S	M	S	S	S
Mercaptoacetic Acid	U	S	U	-	S	M	S	-	S	M	S	U	U	U	U	-	S	U	U	S	M	S	U	S	S	S	S	
Methyl Alcohol	S	S	S	U	S	S	M	S	S	S	S	S	U	S	U	M	S	S	S	S	S	S	S	M	S	M	U	
Methylene Chloride	U	U	U	U	M	S	S	U	S	U	U	S	U	U	U	U	U	U	M	U	U	U	S	S	M	U	S	U

## B Chemical Compatibility Chart

CHEMICAL	MATERIAL	ALUMINUM	ANODIC COATING for ALUMINUM	BUNA N	CELLULOSE ACETATE BUTYRATE	POLYURETHANE ROTOR PAINT	COMPOSITE Carbon Fiber/Epoxy	DELRIN®	ETHYLENE PROPYLENE	GLASS	NEOPRENE	NORYL®	NYLON	PET®, POLYCLEAR®, CLEARCRIMP®, CCCLEARCRIMP®	POLYALLOMER	POLYCARBONATE	POLYESTER, GLASS THERMOSET	POLYETHERIMIDE	POLYRTHYLENE	POLYPROPYLENE	POLYSULFONE	POLYVINYL CHLORIDE	RULON A®, TEFLON®	SILICONE RUBBER	STAINLESS STEEL	TITANIUM	TYGON®	VITON®	
Methyl Ethyl Ketone		S	S	U	U	S	S	M	S	S	U	U	S	U	S	U	U	U	S	S	U	U	S	S	S	S	U	U	
Metrizamide®		M	S	S	-	S	S	S	-	S	S	S	S	-	S	S	-	-	S	S	S	S	S	S	M	S	S	S	
Lactic Acid (100%)		-	-	S	-	-	-	-	-	-	M	S	U	-	S	S	S	M	S	S	-	M	S	M	S	S	-	S	
Lactic Acid (20%)		-	-	S	S	-	-	-	-	-	M	S	M	-	S	S	S	S	S	S	S	S	M	S	M	S	S	-	S
N-Butyl Alcohol		S	-	S	U	-	-	S	-	-	S	M	-	U	S	M	S	S	S	S	M	M	S	M	-	S	-	S	
N-Butyl Phthalate		S	S	U	-	S	S	S	-	S	U	U	S	U	U	U	M	-	U	U	S	U	S	M	M	S	U	S	
N, N-Dimethylformamide		S	S	S	U	S	M	S	-	S	S	U	S	U	S	U	U	-	S	S	U	U	S	M	S	S	S	U	
Sodium Borate		M	S	S	S	S	S	S	S	S	S	S	U	S	S	S	S	-	S	S	S	S	S	S	M	S	S	S	
Sodium Bromide		U	S	S	-	S	S	S	-	S	S	S	S	S	S	S	S	-	S	S	S	S	S	S	M	S	S	S	
Sodium Carbonate (2%)		M	U	S	S	S	S	S	S	S	S	S	S	S	S	U	S	S	S	S	S	S	S	S	S	S	S	S	
Sodium Dodecyl Sulfate		S	S	S	-	S	S	S	-	S	S	S	S	S	S	S	-	S	S	S	S	S	S	S	S	S	S	S	
Sodium Hypochlorite (5%)		U	U	M	S	S	M	U	S	S	M	S	S	S	M	S	S	S	S	M	S	S	S	M	U	S	M	S	
Sodium Iodide		M	S	S	-	S	S	S	-	S	S	S	S	S	S	S	S	-	-	S	S	S	S	S	M	S	S	S	
Sodium Nitrate		S	S	S	-	S	S	S	S	S	S	S	S	S	S	S	S	-	S	S	S	S	S	U	S	S	S	S	
Sodium Sulfate		U	S	S	-	S	S	S	S	S	S	S	S	S	S	S	S	S	S	S	S	S	S	S	M	S	S	S	
Sodium Sulfide		S	-	S	S	-	-	-	S	-	-	-	S	S	S	U	U	-	-	S	-	-	-	S	S	M	-	S	
Sodium Sulfite		S	S	S	-	S	S	S	S	M	S	S	S	S	S	S	M	-	S	S	S	S	S	S	S	S	S	S	
Nickel Salts		U	S	S	S	S	S	-	S	S	S	-	-	S	S	S	S	-	S	S	S	S	S	S	M	S	S	S	
Oils (Petroleum)		S	S	S	-	-	-	S	U	S	S	S	S	U	U	M	S	M	U	U	S	S	S	U	S	S	S	S	
Oils (Other)		S	-	S	-	-	-	S	M	S	S	S	S	U	S	S	S	S	U	S	S	S	S	-	S	S	M	S	
Oleic Acid		S	-	U	S	S	S	U	U	S	U	S	S	M	S	S	S	S	S	S	S	S	S	M	U	S	M	M	
Oxalic Acid		U	U	M	S	S	S	U	S	S	S	S	S	U	S	U	S	S	S	S	S	S	S	S	U	M	S	S	
Perchloric Acid (10%)		U	-	U	-	S	U	U	-	S	M	M	-	-	M	U	M	S	M	M	-	M	S	U	-	S	-	S	
Perchloric Acid (70%)		U	U	U	-	-	U	U	-	S	U	M	U	U	M	U	U	U	M	M	U	M	S	U	U	S	U	S	
Phenol (5%)		U	S	U	-	S	M	M	-	S	U	M	U	U	S	U	M	S	M	S	U	U	S	U	M	M	M	S	
Phenol (50%)		U	S	U	-	S	U	M	-	S	U	M	U	U	U	U	U	S	U	M	U	U	S	U	U	U	M	S	
Phosphoric Acid (10%)		U	U	M	S	S	S	U	S	S	S	S	U	-	S	S	S	S	S	S	S	S	S	U	M	U	S	S	
Phosphoric Acid (conc.)		U	U	M	M	-	-	U	S	-	M	S	U	U	M	M	S	S	M	S	M	S	U	M	U	-	S		
Physiologic Media (Serum, Urine)		M	S	S	S	-	-	S	-	S	S	S	S	S	S	S	S	S	S	S	S	S	S	S	S	S	S	S	
Picric Acid		S	S	U	-	S	M	S	S	S	M	S	U	S	S	S	U	S	S	S	S	U	S	U	M	S	M	S	

CHEMICAL	MATERIAL																										
	ALUMINUM	ANODIC COATING for ALUMINUM	BUNA N	CELLULOSE ACETATE BUTYRATE	POLYURETHANE ROTOR PAINT	COMPOSITE Carbon Fiber/Epoxy	DELRIN®	ETHYLENE PROPYLENE	GLASS	NEOPRENE	NORYL®	NYLON	PET®, POLYCLEAR®, CLEARCRIMP®, CCCLEARCRIMP®	POLYALLOMER	POLYCARBONATE	POLYESTER, GLASS THERMOSET	POLYETHERIMIDE	POLYRTHYLENE	POLYPROPYLENE	POLYSULFONE	POLYVINYL CHLORIDE	RULON A®, TEFLON®	SILICONE RUBBER	STAINLESS STEEL	TITANIUM	TYGON®	VITON®
Pyridine (50%)	U	S	U	U	S	U	U	-	U	S	S	U	U	M	U	U	-	U	S	M	U	S	S	U	U	U	U
Rubidium Bromide	M	S	S	-	S	S	S	-	S	S	S	S	S	S	S	-	-	S	S	S	S	S	S	M	S	S	S
Rubidium Chloride	M	S	S	-	S	S	S	-	S	S	S	S	S	S	S	-	-	S	S	S	S	S	S	M	S	S	S
Sucrose	M	S	S	-	S	S	S	S	S	S	S	S	S	S	S	S	S	S	S	S	S	S	S	S	S	S	S
Sucrose, Alkaline	M	S	S	-	S	S	S	-	S	S	S	S	S	S	U	S	S	S	S	S	S	S	S	M	S	S	S
Sulfosalicylic Acid	U	U	S	S	S	S	S	-	S	S	S	U	S	S	S	-	S	S	S	-	S	S	S	U	S	S	S
Nitric Acid (10%)	U	S	U	S	S	U	U	-	S	U	S	U	-	S	S	S	S	S	S	S	S	S	M	S	S	S	S
Nitric Acid (50%)	U	S	U	M	S	U	U	-	S	U	S	U	U	M	M	U	M	M	M	S	S	S	U	S	S	M	S
Nitric Acid (95%)	U	-	U	U	-	U	U	-	-	U	U	U	U	M	U	U	U	U	M	U	U	S	U	S	S	-	S
Hydrochloric Acid (10%)	U	U	M	S	S	S	U	-	S	S	S	U	U	S	U	S	S	S	S	S	S	S	S	U	M	S	S
Hydrochloric Acid (50%)	U	U	U	U	S	U	U	-	S	M	S	U	U	M	U	U	S	S	S	S	M	S	M	U	U	M	M
Sulfuric Acid (10%)	M	U	U	S	S	U	U	-	S	S	M	U	S	S	S	S	S	S	S	S	S	S	U	U	U	S	S
Sulfuric Acid (50%)	M	U	U	U	S	U	U	-	S	S	M	U	U	S	U	U	M	S	S	S	S	S	U	U	U	M	S
Sulfuric Acid (conc.)	M	U	U	U	-	U	U	M	-	-	M	U	U	S	U	U	U	M	S	U	M	S	U	U	U	-	S
Stearic Acid	S	-	S	-	-	-	S	M	S	S	S	S	-	S	S	S	S	S	S	S	S	S	M	M	S	S	S
Tetrahydrofuran	S	S	U	U	S	U	U	M	S	U	U	S	U	U	U	-	M	U	U	U	U	S	U	S	S	U	U
Toluene	S	S	U	U	S	S	M	U	S	U	U	S	U	U	U	S	U	M	U	U	U	S	U	S	U	U	M
Trichloroacetic Acid	U	U	U	-	S	S	U	M	S	U	S	U	U	S	M	-	M	S	S	U	U	S	U	U	U	M	U
Trichloroethane	S	-	U	-	-	-	M	U	-	U	-	S	U	U	U	U	U	U	U	U	U	S	U	-	S	-	S
Trichloroethylene	-	-	U	U	-	-	-	U	-	U	-	S	U	U	U	U	U	U	U	U	U	S	U	-	U	-	S
Trisodium Phosphate	-	-	-	S	-	-	M	-	-	-	-	-	-	S	-	-	S	S	S	-	-	S	-	-	S	-	S
Tris Buffer (neutral pH)	U	S	S	S	S	S	S	-	S	S	S	S	S	S	S	S	S	S	S	S	S	S	S	S	S	S	S
Triton X-100®	S	S	S	-	S	S	S	-	S	S	S	S	S	S	S	S	S	S	S	S	S	S	S	S	S	S	S
Urea	S	-	U	S	S	S	S	-	-	-	-	S	S	S	M	S	S	S	S	-	S	S	S	M	S	-	S
Hydrogen Peroxide (10%)	U	U	M	S	S	U	U	-	S	S	S	U	S	S	S	M	U	S	S	S	S	S	S	M	S	U	S
Hydrogen Peroxide (3%)	S	M	S	S	S	-	S	-	S	S	S	S	S	S	S	S	M	S	S	S	S	S	S	S	S	S	S
Xylene	S	S	U	S	S	S	M	U	S	U	U	U	U	U	U	M	U	M	U	U	U	S	U	M	S	U	S
Zinc Chloride	U	U	S	S	S	S	U	S	S	S	S	S	S	S	S	S	S	S	S	S	S	S	S	U	S	S	S
Zinc Sulfate	U	S	S	-	S	S	S	S	S	S	S	S	S	S	S	S	S	S	S	S	S	S	S	S	S	S	S
Citric Acid (10%)	M	S	S	M	S	S	M	S	S	S	S	S	S	S	S	S	M	S	S	S	S	S	S	S	S	S	S

## **B** Chemical Compatibility Chart

\*Polyethyleneterephthalate

Key

S Satisfactory

M Moderate attack, may be satisfactory for use in centrifuge depending on length of exposure, speed involved, etc.; suggest testing under actual conditions of use.

U Unsatisfactory, not recommended.

-- Performance unknown; suggest testing, using sample to avoid loss of valuable material.

Chemical resistance data is included only as a guide to product use. Because no organized chemical resistance data exists for materials under the stress of centrifugation, when in doubt we recommend pretesting sample lots.

## Contact Information

United States	866-9-THERMO
	+1 866 984 3766

Canada	+1 866 984 3766
--------	-----------------

Austria	+43 1 801 400
---------	---------------

Belgium	+32 2 482 30 30
---------	-----------------

Germany	08001 536 376
	+49 6184 90 6940

France	+33 2 2803 2180
	+33 2 2803 2000

Italy	+39 02 02 95059 341
-------	---------------------

Netherlands	+31 76 571 4440
-------------	-----------------

Nordic / Baltic Countries	+35 89 329 100
---------------------------	----------------

Russia	+7 (812) 703 42 15
--------	--------------------

## **C** Contact Information

Spain +34 932 23 09 18

---

Portugal +34 932 23 09 18

---

Switzerland +41 44 454 12 12

---

UK / Ireland +44 870 609 9203

---

China +86 21 6865 4588

---

+86 10 8419 3588

---

India +91 22 6716 2200

---

Japan +81 45 453 9220

---

Other Asian Countries +852 2885 4613

---

Latin America +1 866 984 3766

---

Other Countries +49 6184 90 6940

---

+33 2 2803 2180

---

# Index

- A**
- Accessories ..... 2-1
  - Aerosol-tight rotors ..... 3-3
  - Autoclaving ..... 5-5
- B**
- Before a run ..... 4-2
- C**
- Care ..... 5-1
  - Chemical Compatibility Chart ..... B-1
  - Cleaning ..... 5-2
  - Cleaning agents ..... 5-3
  - Contact Information ..... C-1
  - Cycle counter ..... 4-4
- D**
- Decontamination ..... 5-4
  - Disinfection ..... 5-3
- H**
- Heraeus 120V 60Hz refrigerated ..... 1-3
  - Heraeus 120V 60Hz ventilated ..... 1-3
  - Heraeus 230V 50Hz/60Hz refrigerated ..... 1-2
  - Heraeus 230V 50Hz/60Hz ventilated ..... 1-2
- I**
- Improper loading ..... 4-2
- M**
- Maintenance ..... 5-1
  - Maximum loading ..... 4-3
- P**
- Precautions ..... iii
  - Preface ..... iii
  - Proper loading ..... 4-2
- R**
- RCF-values ..... A-1
  - Removing the rotor ..... 3-3
  - Rotor installation ..... 3-2
- S**
- Scope of supply ..... iii
  - Service technician ..... 5-5
  - Sorvall 100V 50/60Hz refrigerated ..... 1-6
  - Sorvall 100V 50/60Hz ventilated ..... 1-6
  - Sorvall 120V 60Hz refrigerated ..... 1-5
  - Sorvall 120V 60Hz ventilated ..... 1-5
  - Sorvall 230V 50Hz/60Hz refrigerated ..... 1-4
  - Sorvall 230V 50Hz/60Hz ventilated ..... 1-4
- T**
- Thermo Scientific 120V 60Hz refrigerated ..... 1-8
  - Thermo Scientific 120V 60Hz ventilated ..... 1-8
  - Thermo Scientific 230V 50Hz/60Hz refrigerated .. 1-7
  - Thermo Scientific 230V 50Hz/60Hz ventilated .... 1-7

