



Thermo Fisher Scientific

TX-750

Instruction Manual

50119938-4

October 2009

© 2009 Thermo Fisher Scientific Inc. All rights reserved.

AutoLock™ is either a registered trademark or a trademark of Thermo Fisher Scientific.

All other trademarks are the property of Thermo Fisher Scientific Inc. and its subsidiaries.

Thermo Fisher Scientific Inc. provides this document to its customers with a product purchase to use in the product operation. This document is copyright protected and any reproduction of the whole or any part of this document is strictly prohibited, except with the written authorization of Thermo Fisher Scientific Inc.

The contents of this document are subject to change without notice. All technical information in this document is for reference purposes only. System configurations and specifications in this document supersede all previous information received by the purchaser.

Thermo Fisher Scientific Inc. makes no representations that this document is complete, accurate or error-free and assumes no responsibility and will not be liable for any errors, omissions, damage or loss that might result from any use of this document, even if the information in the document is followed properly.

This document is not part of any sales contract between Thermo Fisher Scientific Inc. and a purchaser. This document shall in no way govern or modify any Terms and Conditions of Sale, which Terms and Conditions of Sale shall govern all conflicting information between the two documents.

Release history: 50119938-4 printed in October 2009.

For Research Use Only. Not for use in diagnostic procedures.

Centre of Emergency Preparedness and Response
Health Protection Agency
Porton Down
Salisbury
Wiltshire SP4 0JG
United Kingdom



Certificate of Containment Testing

Containment testing of Thermo Scientific swing out bucket rotor 75003607 and bucket 75003614

Report No. 59-08 D

Report prepared for: Thermo Fisher
Issue Date: 15th January 2009

Test Summary

A Thermo Scientific 75003614 centrifuge bucket with aerosol tight lid (Max speed 4,700 rpm) was supplied by Thermo Fisher and containment tested at 4,700 rpm using the method described in Annex AA of EN 61010-2-020. The rotor was shown to contain a spill when tested in triplicate.

Report Written By

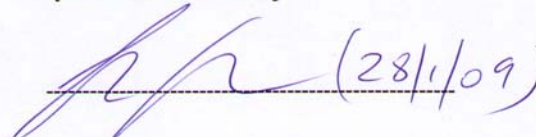

Report Authorised By

 (28/1/09)

Centre of Emergency Preparedness and Response
Health Protection Agency
Porton Down
Salisbury
Wiltshire SP4 0JG
United Kingdom



Certificate of Containment Testing

Containment testing of Thermo Scientific Swing out bucket rotor 75003607 and bucket 75003608

Report No. 59-08 C

Report prepared for: Thermo Fisher
Issue Date: 15th January 2009

Test Summary

A Thermo Scientific 75003608 centrifuge bucket with aerosol tight lid (Max speed 4,700 rpm) was supplied by Thermo Fisher and containment tested at 4,700 rpm using the method described in Annex AA of EN 61010-2-020. The rotor was shown to contain a spill when tested in triplicate.

Report Written By

A handwritten signature in blue ink, written over a horizontal dashed line.

Report Authorised By

A handwritten signature in blue ink, written over a horizontal dashed line, with the date "(23/1/09)" written to the right of the signature.

Table of Contents

Preface	iii
Scope of Supply	iii
Precautions	iii
Chapter 1 Rotor Specifications	1-1
Heraeus	1-2
Heraeus 230V 50Hz/60Hz Round bucket 75003608	1-2
4x750Heraeus 230V 50Hz/60Hz rectangular bucket 75003614	1-3
Heraeus 120V 60Hz Round bucket 75003608	1-4
Heraeus 120V 60Hz rectangular bucket 75003614	1-5
Sorvall	1-6
Sorvall 230V 50Hz/60Hz Round bucket 75003608	1-6
Sorvall 230V 50Hz/60Hz rectangular bucket 75003614	1-7
Sorvall 120V 60Hz Round bucket 75003608	1-8
Sorvall 120V 60Hz rectangular bucket 75003614	1-9
Sorvall 100V 50/60Hz Round bucket 75003608	1-10
Sorvall 100V 50/60Hz rectangular bucket 75003614	1-11
Thermo Scientific	1-12
Thermo Scientific 230V 50Hz/60Hz Round bucket 75003608	1-12
Thermo Scientific 230V 50Hz/60Hz rectangular bucket 75003614	1-13
Thermo Scientific 120V 60Hz Round bucket 75003608	1-14
Thermo Scientific 120V 60Hz rectangular bucket 75003614	1-15
Chapter 2 Accessories	2-1
Chapter 3 AutoLock™	3-1
Rotor Installation	3-2
Removing the Rotor	3-3
Chapter 4 Rotor Loading	4-1
Before a Run	4-2
Proper Loading	4-2
Improper Loading	4-3
Maximum Loading	4-3
Cycle Counter	4-4
Chapter 5 Aerosol-tight Applications	5-1
Basic Principles	5-2
Fill Level	5-2
Checking the aerosol Tightness	5-2

Chapter 6	Maintenance and Care	6-1
	Cleaning Intervals	6-2
	Cleaning	6-2
	Disinfection	6-3
	Decontamination	6-4
	Autoclaving	6-5
	Service of Thermo Fisher Scientific	6-6
	RCF-Values	A-1
	Rectangular buckets 75003614	A-1
	Round bucket 75003608	A-2
	Chemical Compatibility Chart	B-1
	Warranty and recommended Service Life	C-1
	Contact Information	D-1

Preface

Before starting to use the rotor, read through these instruction manual carefully and follow the instructions.

The information contained in these instruction manual is the property of Thermo Fisher Scientific; it is forbidden to copy or pass on this information without explicit approval.

Failure to follow the instructions and safety information in this instruction manual will result in the expiration of the seller's warranty.

Scope of Supply

Article Number		Quantity	Check
75003607	TX-750	1	<input type="checkbox"/>
76003500	Rubber seal grease	1	<input type="checkbox"/>
75003786	Bolt grease	1	<input type="checkbox"/>
50120038	Instruction Manual	1	<input type="checkbox"/>

If any parts are missing, please contact the nearest Thermo Fisher Scientific representative.

Precautions

In order to ensure safe operation of the TX-750, the following general safety regulations must be followed:

- Do not remove the magnet at the rotor bottom
- Do not use rotors which show any signs of corrosion and/or cracks. Do not touch the electronic components of the rotor and do not make any changes to the electronic or mechanical components.
- Use only with rotors which have been loaded properly.
- Never overload the rotor.

Preface

- Use only accessories which have been approved by Thermo Fisher Scientific. Exceptions to this rule are commercially available glass or plastic centrifuge tubes, provided they have been approved for the speed or the RCF value of the rotor.
- Please observe the safety instructions.

Please pay particular attention to the following aspects:

- Rotor installation: Check that the rotor is locked properly into place before operating the centrifuge.
- Always balance the samples.

Maximum sample density at maximum speed: $1,2 \frac{g}{cm^3}$



This symbol refers to general hazards.
ATTENTION means that material damage could occur.
WARNING means that injuries or material damage or contamination could occur.



This symbol refers to biological hazards.
Observe the information contained in the instruction manual to keep yourself and your environment safe.

Rotor Specifications

Contents

- “Heraeus” on page 1-2
- “Sorvall” on page 1-6
- “Thermo Scientific” on page 1-12

Heraeus

Table 1-1. Heraeus 230V 50Hz/60Hz Round bucket 75003608

Centrifuge	Heraeus Multifuge X3	Heraeus Multifuge X3 F	Heraeus Megafuge 40
Catalog #	75004,500	75004530	75004503
Weight empty [kg]	7.4	7.4	7.4
max. cycle number	50,000	50,000	50,000
Maximum permissible load [g]	4x800	4x800	4x800
maximum speed n_{max} [rpm]	4,700	4,700	4,700
maximum RCF value at n_{max}	4,816	4,816	4,816
max. / min. radius [cm]	19.5 / 8.3	19.5 / 8.3	19.5 / 8.3
Pitch angle [°]	90	90	90
Accel. / braking time [s]	55 / 55	55 / 55	55 / 55
sample heating at n_{max} [° C] referred to ambient temperature of 23 °C, running time 120 minutes	11	11	11
aerosol-tight*	yes	yes	yes
permissible temperature range autoclavable °C	121	121	121

*tested by HPA, Porton-down, UK

Centrifuge	Heraeus Multifuge X3R	Heraeus Multifuge X3 FR	Heraeus Megafuge 40R
Catalog #	75004515	75004536	75004518
Weight empty [kg]	7.4	7.4	7.4
max. cycle number	50,000	50,000	50,000
Maximum permissible load [g]	4x800	4x800	4x800
maximum speed n_{max} [rpm]	4,700	4,700	4,700
maximum RCF value at n_{max}	4,816	4,816	4,816
max. / min. radius [cm]	19.5 / 8.3	19.5 / 8.3	19.5 / 8.3
Pitch angle [°]	90	90	90
Accel. / braking time [s]	50 / 55	50 / 55	50 / 55
aerosol-tight*	yes	yes	yes
permissible temperature range autoclavable °C	121	121	121

*tested by HPA, Porton-down, UK

Table 1-2. 4x750Heraeus 230V 50Hz/60Hz rectangular bucket 75003614

Centrifuge	Heraeus Multifuge X3	Heraeus Multifuge X3 F	Heraeus Megafuge 40
Catalog #	75004,500	75004530	75004503
Weight empty [kg]	6,8	6,8	6,8
max. cycle number	50,000	50,000	50,000
Maximum permissible load [g]	4x750	4x750	4x750
maximum speed n_{max} [rpm]	4,500	4,500	4,500
maximum RCF value at n_{max}	4,415	4,415	4,415
max. / min. radius [cm]	19.5 / 8.9	19.5 / 8.9	19.5 / 8.9
Pitch angle [°]	90	90	90
Accel. / braking time [s]	45 / 50	45 / 50	45 / 50
sample heating at n_{max} [° C] referred to ambient temperature of 23 °C, running time 120 minutes	11	11	11
aerosol-tight*	yes	yes	yes
permissible temperature range autoclavable °C	121	121	121

*Tested by HPA, Porton-down, UK

Centrifuge	Heraeus Multifuge X3R	Heraeus Multifuge X3 FR	Heraeus Megafuge 40R
Catalog #	75004515	75004536	75004518
Weight empty [kg]	6,8	6,8	6,8
max. cycle number	50,000	50,000	50,000
Maximum permissible load [g]	4x750	4x750	4x750
maximum speed n_{max} [rpm]	4,500	4,500	4,500
maximum RCF value at n_{max}	4,415	4,415	4,415
max. / min. radius [cm]	19.5 / 8.9	19.5 / 8.9	19.5 / 8.9
Pitch angle [°]	90	90	90
Accel. / braking time [s]	40 / 50	40 / 50	40 / 50
aerosol-tight*	yes	yes	yes
permissible temperature range autoclavable °C	121	121	121

*Tested by HPA, Porton-down, UK

1 Rotor Specifications

Heraeus

Table 1-3. Heraeus 120V 60Hz Round bucket 75003608

Centrifuge	Heraeus Multifuge X3	Heraeus Multifuge X3 F	Heraeus Megafuge 40
Catalog #	75004501	75004531	75004504
Weight empty [kg]	7.4	7.4	7.4
max. cycle number	50,000	50,000	50,000
Maximum permissible load [g]	4x800	4x800	4x800
maximum speed n_{max} [rpm]	4,700	4,700	4,700
maximum RCF value at n_{max}	4,816	4,816	4,816
max. / min. radius [cm]	19.5 / 8.3	19.5 / 8.3	19.5 / 8.3
Pitch angle [°]	90	90	90
Accel. / braking time [s]	90 / 60	90 / 60	90 / 60
sample heating at n_{max} [°C] referred to ambient temperature of 23 °C, running time 120 minutes	11	11	11
aerosol-tight*	yes	yes	yes
permissible temperature range autoclavable °C	121	121	121

*tested by HPA, Porton-down, UK

Centrifuge	Heraeus Multifuge X3R	Heraeus Multifuge X3 FR	Heraeus Megafuge 40R
Catalog #	75004516	75004537	75004519
Weight empty [kg]	7.4	7.4	7.4
max. cycle number	50,000	50,000	50,000
Maximum permissible load [g]	4x800	4x800	4x800
maximum speed n_{max} [rpm]	4,300	4,300	4,300
maximum RCF value at n_{max}	4,031	4,031	4,031
max. / min. radius [cm]	19.5 / 8.3	19.5 / 8.3	19.5 / 8.3
Pitch angle [°]	90	90	90
Accel. / braking time [s]	75 / 60	75 / 60	75 / 60
aerosol-tight*	yes	yes	yes
permissible temperature range autoclavable °C	121	121	121

*tested by HPA, Porton-down, UK

Table 1-4. Heraeus 120V 60Hz rectangular bucket 75003614

Centrifuge	Heraeus Multifuge X3	Heraeus Multifuge X3 F	Heraeus Megafuge 40
Catalog #	75004501	75004531	75004504
Weight empty [kg]	6,8	6,8	6,8
max. cycle number	50,000	50,000	50,000
Maximum permissible load [g]	4x750	4x750	4x750
maximum speed n_{max} [rpm]	4,300	4,300	4,300
maximum RCF value at n_{max}	4,031	4,031	4,031
max. / min. radius [cm]	19.5 / 8.9	19.5 / 8.9	19.5 / 8.9
Pitch angle [°]	90	90	90
Accel. / braking time [s]	70 / 50	70 / 50	70 / 50
sample heating at n_{max} [° C] referred to ambient temperature of 23 °C, running time 120 minutes	8	8	8
aerosol-tight*	yes	yes	yes
permissible temperature range autoclavable °C	121	121	121

*Tested by HPA, Porton-down, UK

Centrifuge	Heraeus Multifuge X3R	Heraeus Multifuge X3 FR	Heraeus Megafuge 40R
Catalog #	75004516	75004537	75004519
Weight empty [kg]	6,8	6,8	6,8
max. cycle number	50,000	50,000	50,000
Maximum permissible load [g]	4x750	4x750	4x750
maximum speed n_{max} [rpm]	4,300	4,300	4,300
maximum RCF value at n_{max}	4,031	4,031	4,031
max. / min. radius [cm]	19.5 / 8.9	19.5 / 8.9	19.5 / 8.9
Pitch angle [°]	90	90	90
Accel. / braking time [s]	65 / 50	65 / 50	65 / 50
aerosol-tight*	yes	yes	yes
permissible temperature range autoclavable °C	121	121	121

*Tested by HPA, Porton-down, UK

1 Rotor Specifications

Sorvall

Sorvall

Table 1-5. Sorvall 230V 50Hz/60Hz Round bucket 75003608

Centrifuge	Sorvall Legend XT	Sorvall Legend XF	Sorvall ST 40
Catalog #	75004505	75004532	75004509
Weight empty [kg]	7.4	7.4	7.4
max. cycle number	50,000	50,000	50,000
Maximum permissible load [g]	4x800	4x800	4x800
maximum speed n_{max} [rpm]	4,700	4,700	4,700
maximum RCF value at n_{max}	4,816	4,816	4,816
max. / min. radius [cm]	19.5 / 8.3	19.5 / 8.3	19.5 / 8.3
Pitch angle [°]	90	90	90
Accel. / braking time [s]	55 / 55	55 / 55	55 / 55
sample heating at n_{max} [° C] referred to ambient temperature of 23 °C, running time 120 minutes	11	11	11
aerosol-tight*	yes	yes	yes
permissible temperature range autoclavable °C	121	121	121

* tested by HPA, Porton-down, UK

Centrifuge	Sorvall Legend XTR	Sorvall Legend XFR	Sorvall ST 40R
Catalog #	75004520	75004538	75004524
Weight empty [kg]	7.4	7.4	7.4
max. cycle number	50,000	50,000	50,000
Maximum permissible load [g]	4x800	4x800	4x800
maximum speed n_{max} [rpm]	4,700	4,700	4,700
maximum RCF value at n_{max}	4,816	4,816	4,816
max. / min. radius [cm]	19.5 / 8.3	19.5 / 8.3	19.5 / 8.3
Pitch angle [°]	90	90	90
Accel. / braking time [s]	50 / 55	50 / 55	50 / 55
aerosol-tight*	yes	yes	yes
permissible temperature range autoclavable °C	121	121	121

* tested by HPA, Porton-down, UK

Table 1-6. Sorvall 230V 50Hz/60Hz rectangular bucket 75003614

Centrifuge	Sorvall Legend XT	Sorvall Legend XF	Sorvall ST 40
Catalog #	75004505	75004532	75004509
Weight empty [kg]	6,8	6,8	6,8
max. cycle number	50,000	50,000	50,000
Maximum permissible load [g]	4x750	4x750	4x750
maximum speed n_{max} [rpm]	4,500	4,500	4,500
maximum RCF value at n_{max}	4,415	4,415	4,415
max. / min. radius [cm]	19.5 / 8.9	19.5 / 8.9	19.5 / 8.9
Pitch angle [°]	90	90	90
Accel. / braking time [s]	45 / 50	45 / 50	45 / 50
sample heating at n_{max} [° C] referred to ambient temperature of 23 °C, running time 120 minutes	11	11	11
aerosol-tight*	yes	yes	yes
permissible temperature range autoclavable °C	121	121	121

*Tested by HPA, Porton-down, UK

Centrifuge	Sorvall Legend XTR	Sorvall Legend XFR	Sorvall ST 40R
Catalog #	75004520	75004538	75004524
Weight empty [kg]	6,8	6,8	6,8
max. cycle number	50,000	50,000	50,000
Maximum permissible load [g]	4x750	4x750	4x750
maximum speed n_{max} [rpm]	4,500	4,500	4,500
maximum RCF value at n_{max}	4,415	4,415	4,415
max. / min. radius [cm]	19.5 / 8.9	19.5 / 8.9	19.5 / 8.9
Pitch angle [°]	90	90	90
Accel. / braking time [s]	40 / 50	40 / 50	40 / 50
aerosol-tight*	yes	yes	yes
permissible temperature range autoclavable °C	121	121	121

*Tested by HPA, Porton-down, UK

1 Rotor Specifications

Sorvall

Table 1-7. Sorvall 120V 60Hz Round bucket 75003608

Centrifuge	Sorvall Legend XT	Sorvall Legend XF	Sorvall ST 40
Catalog #	75004506	75004533	75004510
Weight empty [kg]	7.4	7.4	7.4
max. cycle number	50,000	50,000	50,000
Maximum permissible load [g]	4x800	4x800	4x800
maximum speed n_{max} [rpm]	4,700	4,700	4,700
maximum RCF value at n_{max}	4,816	4,816	4,816
max. / min. radius [cm]	19.5 / 8.3	19.5 / 8.3	19.5 / 8.3
Pitch angle [°]	90	90	90
Accel. / braking time [s]	90 / 60	90 / 60	90 / 60
sample heating at n_{max} [° C] referred to ambient temperature of 23 °C, running time 120 minutes	11	11	11
aerosol-tight*	yes	yes	yes
permissible temperature range autoclavable °C	121	121	121

*Tested by HPA, Porton-down, UK

Centrifuge	Sorvall Legend XTR	Sorvall Legend XFR	Sorvall ST 40R
Catalog #	75004521	75004539	75004525
Weight empty [kg]	7.4	7.4	7.4
max. cycle number	50,000	50,000	50,000
Maximum permissible load [g]	4x800	4x800	4x800
maximum speed n_{max} [rpm]	4,700	4,700	4,700
maximum RCF value at n_{max}	4,816	4,816	4,816
max. / min. radius [cm]	19.5 / 8.3	19.5 / 8.3	19.5 / 8.3
Pitch angle [°]	90	90	90
Accel. / braking time [s]	75 / 60	75 / 60	75 / 60
aerosol-tight*	yes	yes	yes
permissible temperature range autoclavable °C	121	121	121

*Tested by HPA, Porton-down, UK

Table 1-8. Sorvall 120V 60Hz rectangular bucket 75003614

Centrifuge	Sorvall Legend XT	Sorvall Legend XF	Sorvall ST 40
Catalog #	75004506	75004533	75004510
Weight empty [kg]	6,8	6,8	6,8
max. cycle number	50,000	50,000	50,000
Maximum permissible load [g]	4x750	4x750	4x750
maximum speed n_{max} [rpm]	4,300	4,300	4,300
maximum RCF value at n_{max}	4,031	4,031	4,031
max. / min. radius [cm]	19.5 / 8.9	19.5 / 8.9	19.5 / 8.9
Pitch angle [°]	90	90	90
Accel. / braking time [s]	70 / 50	70 / 50	70 / 50
sample heating at n_{max} [° C] referred to ambient temperature of 23 °C, running time 120 minutes	8	8	8
aerosol-tight*	yes	yes	yes
permissible temperature range autoclavable °C	121	121	121

*Tested by HPA, Porton-down, UK

Centrifuge	Sorvall Legend XTR	Sorvall Legend XFR	Sorvall ST 40R
Catalog #	75004521	75004539	75004525
Weight empty [kg]	6,8	6,8	6,8
max. cycle number	50,000	50,000	50,000
Maximum permissible load [g]	4x750	4x750	4x750
maximum speed n_{max} [rpm]	4,300	4,300	4,300
maximum RCF value at n_{max}	4,031	4,031	4,031
max. / min. radius [cm]	19.5 / 8.9	19.5 / 8.9	19.5 / 8.9
Pitch angle [°]	90	90	90
Accel. / braking time [s]	65 / 50	65 / 50	65 / 50
aerosol-tight*	yes	yes	yes
permissible temperature range autoclavable °C	121	121	121

*Tested by HPA, Porton-down, UK

1 Rotor Specifications

Sorvall

Table 1-9. Sorvall 100V 50/60Hz Round bucket 75003608

Centrifuge	Sorvall Legend XT	Sorvall Legend XF	Sorvall ST 40
Catalog #	75004507	75004534	75004511
Weight empty [kg]	7.4	7.4	7.4
max. cycle number	50,000	50,000	50,000
Maximum permissible load [g]	4x800	4x800	4x800
maximum speed n_{max} [rpm]	4,500	4,500	4,500
maximum RCF value at n_{max}	4,415	4,415	4,415
max. / min. radius [cm]	19.5 / 8.3	19.5 / 8.3	19.5 / 8.3
Pitch angle [°]	90	90	90
Accel. / braking time [s]	80 / 60	80 / 60	80 / 60
sample heating at n_{max} [°C] referred to ambient temperature of 23 °C, running time 120 minutes	10	10	10
aerosol-tight*	yes	yes	yes
permissible temperature range autoclavable °C	121	121	121

* Tested by HPA, Porton-down, UK

Centrifuge	Sorvall Legend XTR	Sorvall Legend XFR	Sorvall ST 40R
Catalog #	75004522	75004540	75004526
Weight empty [kg]	7.4	7.4	7.4
max. cycle number	50,000	50,000	50,000
Maximum permissible load [g]	4x800	4x800	4x800
maximum speed n_{max} [rpm]	4,500	4,500	4,500
maximum RCF value at n_{max}	4,415	4,415	4,415
max. / min. radius [cm]	19.5 / 8.3	19.5 / 8.3	19.5 / 8.3
Pitch angle [°]	90	90	90
Accel. / braking time [s]	80 / 60	80 / 60	80 / 60
aerosol-tight*	yes	yes	yes
permissible temperature range autoclavable °C	121	121	121

* Tested by HPA, Porton-down, UK

Table 1-10. Sorvall 100V 50/60Hz rectangular bucket 75003614

Centrifuge	Sorvall Legend XT	Sorvall Legend XF	Sorvall ST 40
Catalog #	75004507	75004534	75004511
Weight empty [kg]	6,8	6,8	6,8
max. cycle number	50,000	50,000	50,000
Maximum permissible load [g]	4x750	4x750	4x750
maximum speed n_{max} [rpm]	4,100	4,100	4,100
maximum RCF value at n_{max}	3,665	3,665	3,665
max. / min. radius [cm]	19.5 / 8.3	19.5 / 8.3	19.5 / 8.9
Pitch angle [°]	90	90	90
Accel. / braking time [s]	65 / 50	65 / 50	65 / 50
sample heating at n_{max} [° C] referred to ambient temperature of 23 °C, running time 120 minutes	8	8	8
aerosol-tight*	yes	yes	yes
permissible temperature range autoclavable °C	121	121	121

*tested by HPA, Porton-down, UK

Centrifuge	Sorvall Legend XTR	Sorvall Legend XFR	Sorvall ST 40R
Catalog #	75004522	75004540	75004526
Weight empty [kg]	6,8	6,8	6,8
max. cycle number	50,000	50,000	50,000
Maximum permissible load [g]	4x750	4x750	4x750
maximum speed n_{max} [rpm]	4,100	4,100	4,100
maximum RCF value at n_{max}	3,665	3,665	3,665
max. / min. radius [cm]	19.5 / 8.9	19.5 / 8.9	19.5 / 8.9
Pitch angle [°]	90	90	90
Accel. / braking time [s]	65 / 50	65 / 50	65 / 50
aerosol-tight*	yes	yes	yes
permissible temperature range autoclavable °C	121	121	121

*tested by HPA, Porton-down, UK

Thermo Scientific

Table 1-11. Thermo Scientific 230V 50Hz/60Hz Round bucket 75003608

Centrifuge	Thermo Scientific SL 40	Thermo Scientific SL 40 F
Catalog #	75004512	75004542
Weight empty [kg]	7.4	7.4
max. cycle number	50,000	50,000
Maximum permissible load [g]	4x800	4x800
maximum speed n_{max} [rpm]	4,700	4,700
maximum RCF value at n_{max}	4,816	4,816
max. / min. radius [cm]	19.5 / 8.3	19.5 / 8.3
Pitch angle [°]	90	90
Accel. / braking time [s]	55 / 55	55 / 55
sample heating at n_{max} [° C] referred to ambient temperature of 23 °C, running time 120 minutes	11	11
aerosol-tight*	yes	yes
permissible temperature range autoclavable °C	121	121

*tested by HPA, Porton-down, UK

Centrifuge	Thermo Scientific SL 40R	Thermo Scientific SL 40 FR
Catalog #	75004527	75004543
Weight empty [kg]	7.4	7.4
max. cycle number	50,000	50,000
Maximum permissible load [g]	4x800	4x800
maximum speed n_{max} [rpm]	4,700	4,700
maximum RCF value at n_{max}	4,816	4,816
max. / min. radius [cm]	19.5 / 8.3	19.5 / 8.3
Pitch angle [°]	90	90
Accel. / braking time [s]	50 / 55	50 / 55
aerosol-tight*	yes	yes
permissible temperature range autoclavable °C	121	121

*tested by HPA, Porton-down, UK

Table 1-12. Thermo Scientific 230V 50Hz/60Hz rectangular bucket 75003614

Centrifuge	Thermo Scientific SL 40	Thermo Scientific SL 40 F
Catalog #	75004512	75004542
Weight empty [kg]	6,8	6,8
max. cycle number	50,000	50,000
Maximum permissible load [g]	4x750	4x750
maximum speed n_{max} [rpm]	4,500	4,500
maximum RCF value at n_{max}	4,415	4,415
max. / min. radius [cm]	19.5 / 8.9	19.5 / 8.9
Pitch angle [°]	90	90
Accel. / braking time [s]	45 / 50	45 / 50
sample heating at n_{max} [° C] referred to ambient temperature of 23 °C, running time 120 minutes	11	11
aerosol-tight*	yes	yes
permissible temperature range autoclavable °C	121	121

*Tested by HPA, Porton-down, UK

Centrifuge	Thermo Scientific SL 40R	Thermo Scientific SL 40 FR
Catalog #	75004527	75004543
Weight empty [kg]	6,8	6,8
max. cycle number	50,000	50,000
Maximum permissible load [g]	4x750	4x750
maximum speed n_{max} [rpm]	4,500	4,500
maximum RCF value at n_{max}	4,415	4,415
max. / min. radius [cm]	19.5 / 8.9	19.5 / 8.9
Pitch angle [°]	90	90
Accel. / braking time [s]	40 / 50	40 / 50
aerosol-tight*	yes	yes
permissible temperature range autoclavable °C	121	121

*Tested by HPA, Porton-down, UK

1 Rotor Specifications

Thermo Scientific

Table 1-13. Thermo Scientific 120V 60Hz Round bucket 75003608

Centrifuge	Thermo Scientific SL 40
Catalog #	75004513
Weight empty [kg]	7.4
max. cycle number	50,000
Maximum permissible load [g]	4x800
maximum speed n_{max} [rpm]	4,700
maximum RCF value at n_{max}	4,816
max. / min. radius [cm]	19.5 / 8.3
Pitch angle [°]	90
Accel. / braking time [s]	90 / 60
sample heating at n_{max} [° C] referred to ambient temperature of 23 °C, running time 120 minutes	11
aerosol-tight*	yes
permissible temperature range autoclavable °C	121

*Tested by HPA, Porton-down, UK

Centrifuge	Thermo Scientific SL 40R
Catalog #	75004528
Weight empty [kg]	7.4
max. cycle number	50,000
Maximum permissible load [g]	4x800
maximum speed n_{max} [rpm]	4,700
maximum RCF value at n_{max}	4,816
max. / min. radius [cm]	19.5 / 8.3
Pitch angle [°]	90
Accel. / braking time [s]	75 / 50
aerosol-tight*	yes
permissible temperature range autoclavable °C	121

*Tested by HPA, Porton-down, UK

Table 1-14. Thermo Scientific 120V 60Hz rectangular bucket 75003614

Centrifuge	Thermo Scientific SL 40
Catalog #	75004513
Weight empty [kg]	6,8
max. cycle number	50,000
Maximum permissible load [g]	4x750
maximum speed n_{max} [rpm]	4,300
maximum RCF value at n_{max}	4,031
max. / min. radius [cm]	19.5 / 8.9
Pitch angle [°]	90
Accel. / braking time [s]	70 / 50
sample heating at n_{max} [° C] referred to ambient temperature of 23 °C, running time 120 minutes	8
aerosol-tight*	yes
permissible temperature range autoclavable °C	121

* Tested by HPA, Porton-down, UK

Centrifuge	Thermo Scientific SL 40R
Catalog #	75004528
Weight empty [kg]	6,8
max. cycle number	50,000
Maximum permissible load [g]	4x750
maximum speed n_{max} [rpm]	4,300
maximum RCF value at n_{max}	4,031
max. / min. radius [cm]	19.5 / 8.9
Pitch angle [°]	90
Accel. / braking time [s]	65 / 50
aerosol-tight*	yes
permissible temperature range autoclavable °C	121

* Tested by HPA, Porton-down, UK

Accessories

Contents

- „Rotor data“ on page 2-2
- „Accessories for round bucket“ on page 2-2
- „Rotor data“ on page 2-4
- „Accessories for rectangular bucket“ on page 2-4

Thermo Scientific General Purpose Rotors

TX-750 Round Buckets

TX-750 Swinging Bucket Aluminum Rotor with Round Buckets



Rotor Specifications	
Capacity (ml)	4 x 750
Tube Dimensions (mm)	98 x 133
Angle °	90
Maximum Speed (rpm)	4,700
K Factor	9783
Net Weight (kg)	7.4

RCF/Radius	RCF (x g)	Radius (cm)
Maximum	4.816	19.5
Minimum	2.050	8.3



TX-750 Rotor Packages

Cat. No.	Description
75003607	TX-750 High Capacity Swing-Out Rotor without buckets
75003608	Round Buckets (set of 4)
75003609	Sealing Caps for Round Buckets (set of 4)
75003610	Replacement O-rings for 75003609 Sealing Caps (set of 4)

Accessories

Cat. No.	Description
75003617	Set of 4 Non-Sealed Microplate Carriers for Microplates or T-75 Nunc Easy Flasks

Tube Ordering Information

Cat. No.	Tube Vol. (ml)	Vol. Fill (ml)	Description	Qty.	Max. Speed (rpm)	Dims ØxL (mm)	Sealing Assembly Required:			Adapters Required:			Accessories Required:		
							Cat. No.	Qty /Pkg	Description	Cat. No.	Qty /Pkg	No. of Places	Cat. No.	Qty	No. of Places
75003699	750	750	PP Bio-Bottle	12	4,700	98x133	Included	12	PP Sealing	-	-	-	-	-	-
-	500	500	Corning Conical	-	4,700	98x147	-	-	-	Corning Cushion #431124	-	-	-	-	-
3141-0250	250	250	PP Oak Ridge Bottle	4	4,700	62.5x139	Included	4	PP Sealing	75003710	4	1	-	-	-
3140-0250	250	250	PC OakRidge Bottle	4	4,700	62.5x139	Included	4	PP Sealing	75003710	4	1	-	-	-
-	225	225	BD Conical	-	-	62.5x139	-	-	-	75003710+ BD Cushion #352090	4	1	-	-	-
376813	200	200	Nunc Conical	4	-	62.5x139	Included	4	PP Sealing	75003710+ 377585	4	1	-	-	-
3143-0175	175	175	PP Nalgene Conical	4	-	62.5x139	Included	4	PP Sealing	75003710+ DS3126-0175	4	1	-	-	-
3144-0175	175	175	PC Nalgene Conical	4	-	62.5x139	Included	4	PP Sealing	75003710+ DS3126-0175	4	1	-	-	-
76009007	100	75	Glass Bottle	10	4,000	45x123	-	-	-	75003713	4	1	-	-	-
76009084	100	75	PP Bottle	1	4,700	45x98	-	-	-	75003713	4	1	-	-	-
76009095	100	75	PC Bottle	1	4,700	45 x98	-	-	-	75003713	4	1	-	-	-
334959	50	50	Nunc Conical	25	4,700	29.5x120	Included	25	PP Sealing	75003638	4	7	-	-	* Max Capacity may vary by tube brand
334959	50	50	Nunc Conical	25	4,700	29.5x120	Included	25	PP Sealing	75003714	4	3	-	-	Individually sealed tube
3139-0050	50	50	PP Oak Ridge Tube	10	4,700	29x114	Included	10	PP Sealing	75003715	4	7	-	-	-
3138-0050	50	50	PC Oak Ridge Tube	10	4,700	29x114	Included	10	PP Sealing	75003715	4	7	-	-	-

Thermo Scientific General Purpose Rotors

.750 Round Buckets (cont'd)

Tube Ordering Information

Cat. No.	Tube Vol. (ml)	Vol. Fill (ml)	Description	Qty.	Max. Speed (rpm)	Dims ØxL (mm)	Sealing Assembly Required:			Adapters Required:			Accessories Required:	
							Cat. No.	Qty /Pkg	Description	Cat. No.	Qty /Pkg	No. of Places		
3114-0050	50	50	Teflon Oak Ridge Tube	2	4.700	29x114	Included	2	PP Sealing	75003715	4	7	-	-
45500-30	30	25	KIMAX Glass Tube	6	4.700	24x106	-	-	-	75003716	4	7	-	-
366036	15	15	Nunc Conical	50	4.700	17x120	Included	50	PP Sealing	75003639	4	12	-	-
-	15	-	Blood Collection	-	-	16x125	-	-	-	75003719	4	8	*	Inner circle only
45500-15	15	12	KIMAX Glass Tube	50	4.700	17x102	-	-	-	75003719	4	19	-	-
-	14	-	Conical Urine Tube	-	-	18x124	-	-	-	75003718	4	12	-	-
3139-0010	10	8	PP Oak Ridge Tube	10	4.700	16x82	Included	10	PP Sealing	75003719	4	21	-	-
3138-0010	10	8	PC Oak Ridge Tube	10	4.700	16x82	Included	10	PP Sealing	75003719	4	21	-	-
-	10	-	Blood Collection	-	-	16x100	-	-	-	75003719	4	21	-	-
-	7	-	Blood Collection	-	-	13x100	-	-	-	75003723	4	27	-	-
-	5	-	Blood Collection	-	-	13x75	-	-	-	75003723	4	27	-	-
-	5	-	RIA Tubes	-	-	13x75	-	-	-	75003724	4	37	-	-
-	5	-	RIA Decanting Tubes	-	-	13x75	-	-	-	75003732	4	37	-	-
-	1.5/2	-	Conical Microtube	-	-	11x42	-	-	-	75003733	4	48	-	-
-	-	-	T-75 Nunc Easy Flask	-	-	-	-	-	-	75008383	2	1	-	-
-	-	-	T-25 Nun Easy Flask	-	-	-	-	-	-	75008384	2	2	-	-
-	MP	-	Standard Microplates (up to 20mm)	-	-	-	-	-	-	75003617	4	4	-	-
-	MP	-	Deepwell Microplates (up to 40mm)	-	-	-	-	-	-	75003617	4	1	-	-

TX-750 Swinging Bucket Aluminum Rotor with Rectangular Buckets



Rotor Specifications		
Capacity (ml)	4 x 250	
Tube Dimensions (mm)	63 x 130	
Angle °	90	
Maximum Speed (rpm)	5	
K Factor	8,983	
Net Weight (kg)	6.8	
RCF/Radius	RCF (x g)	Radius (cm)
Maximum	4,415	19.5
Minimum	2	8.9



TX-750 Rotor Packages	
Cat. No.	Description
75003607	TX-750 Rotor Body
75003614	Set of 4 250 ml Buckets without Lids
75003615	Set of 4 ClickSeal Lids
75003616	Replacement O-rings for 75003615 Sealing Caps (set of 4)

Accessories	
Cat. No.	Description
75003617	Set of 4 Non-Sealed Microplate Carriers for Microplates or T-75 Nunc Easy Flasks

Tube Ordering Information														
Cat. No.	Tube Vol. (ml)	Vol. Fill (ml)	Description	Qty.	Max. Speed (rpm)	Dims ØxL (mm)	Sealing Assembly Required:			Adapters Required:		Accessories Required:		
							Cat. No.	Qty /Pkg	Description	Cat. No.	Qty /Pkg	No. of Places		
3141-0250	250	250	PP Oak Ridge Bottle	4	4.700	63x130	Included	4	PP Sealing	75003737	4	1	-	-
3140-0250	250	250	PC OakRidge Bottle	4	4.700	63x130	Included	4	PP Sealing	75003737	4	1	-	-
-	150	-	Round Bottom Open Topped Tube	-	-	56x124	-	-	-	75003738	4	1	-	-
76009007	100	75	Glass Bottle	10	4.700	44x100	-	-	-	75003742	4	1	-	-
76009084	100	75	PP Bottle	1	4.700	45x98	-	-	-	75003742	4	1	-	-
76009095	100	75	PC Bottle	1	4.700	45x98	-	-	-	75003742	4	1	-	-
334959	50	50	Nunc Conical	25	4.700	30x121	Included	25	PP Sealing	75003685	4	5	-	-
-	50	-	Round Bottom Open Topped Tube	-	-	35x121	-	-	-	75003749	4	3	-	-
3139-0050	50	50	PP Oak Ridge Tube	10	4.700	29x114	Included	10	PP Sealing	75003750	4	4	-	-
3138-0050	50	50	PC Oak Ridge Tube	10	4.700	29x114	Included	10	PP Sealing	75003750	4	4	-	-
3114-0050	50	50	Teflon Oak Ridge Tube	2	4.700	29x114	Included	2	PP Sealing	75003750	4	4	-	-
-	45	-	Flat or Round Bottom Tube	-	-	30x121	-	-	-	75003750	4	4	-	-
45500-30	30	25	KIMAX Glass Tube	6	4.700	24x106	-	-	-	75003756	4	6	-	-
-	25	-	Universal	-	-	26x121	-	-	-	75003755	4	4	-	-

Thermo Scientific General Purpose Rotors

TX-750 Rectangular Buckets (cont'd)

Tube Ordering Information

Cat. No.	Tube Vol. (ml)	Vol. Fill (ml)	Description	Qty.	Max. Speed (rpm)	Dims ØxL (mm)	Sealing Assembly Required:			Adapters Required:			Accessories Required:		
							Cat. No.	Qty /Pkg	Description	Cat. No.	Qty /Pkg	No. of Places	Cat. No.	Qty /Pkg	No. of Places
-	15	-	Conical Urine Tube	-	-	17x124	-	-	-	75003759	4	9	-	-	
366036	15	15	Nunc Conical	50	4.700	17x120	Included	50	PP Sealing	75003684	4	12	-	-	
-	15	-	Blood Collection	-	-	16x125	-	-	-	75003767	4	16	-	-	
-	14	-	Flanged Round Bottom Tube	-	-	18x121	-	-	-	75003758	4	9	-	-	
3139-0010	10	8	PP Oak Ridge Tube	10		16x82	Included	10	PP Sealing	75003767	4	16	-	-	
3138-0010	10	8	PC Oak Ridge Tube	10		16x82	Included	10	PP Sealing	75003767	4	16	-	-	
-	10	-	Blood Collection	-	-	16x100	-	-	-	75003767	4	16	-	-	
-	7	-	Blood Collection	-	-	13x100	-	-	-	75003768	4	20	-	-	
-	5	-	Blood Collection	-	-	13x75	-	-	-	75003768	4	20	-	-	
-	5	-	RIA Tubes	-	-	13x75	-	-	-	75003769	4	28	-	-	
-	1.5/2	-	Conical Microtube	-	-	11x50	-	-	-	75003770	4	56	-	-	
-	MP	-	Standard Microplates (up to 20mm)	-	-	-	-	-	-	75003617	4	4	-	-	
-	MP	-	Deepwell Microplates (up to 40mm)	-	-	-	-	-	-	75003617	4	1	-	-	

AutoLock™

Contents

- “Rotor Installation” on page 3-2
- “Removing the Rotor” on page 3-3

Rotor Installation



CAUTION Unapproved or incorrectly combined accessories can cause serious damage to the centrifuge.

This rotor is equipped with an AutoLock™-system.

This system is used to automatically lock the rotor to the centrifuge spindle. The rotor does not have to be bolted onto the centrifuge spindle.

Proceed as follows:

1. Open the lid of the centrifuge and if necessary remove any dust, foreign objects or residue from the chamber.
AutoLock™ and o-ring must be clean and undamaged.

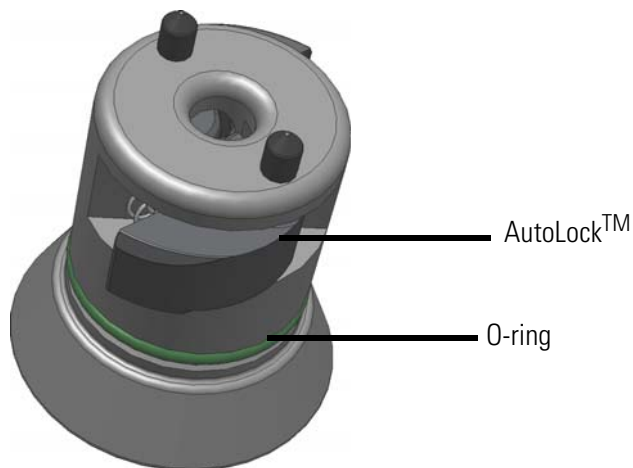

Figure 3-1. AutoLock™

2. Hold the rotor over the centrifuge spindle and let it slide slowly down the centrifuge spindle. The rotor clicks automatically into place.



CAUTION Do not force the rotor onto the centrifuge spindle. If the rotor is very light, then it may be necessary to press it onto the centrifuge spindle with a small amount of pressure.

3. Check if the rotor is properly installed by lifting slightly on the handle. If the rotor can be pulled up, then it must be reclamped to the centrifuge spindle.



WARNING If the rotor cannot be properly locked in place after several attempts, then the AutoLock™ is defective and you are not permitted to operate the rotor. Check for any damage to the rotor, damaged rotors must not be used. Keep the hub area clear of objects.



CAUTION Check that the rotor is properly locked on the centrifuge spindle before each use by pulling it a its handle.



Be sure to check all seals before starting any aerosol-tight applications.

4. Close the centrifuge door.

Removing the Rotor

To remove the rotor, proceed as follows:

1. Open the centrifuge door.
2. Grab the rotor handle with both hands and press against the green AutoLock™ button. At the same time, pull the rotor directly upwards with both hands and remove it from the centrifuge spindle. Make sure not to jam the rotor while doing this.



Figure 4. Handling of AutoLock™

Rotor Loading

Contents

- “Before a Run” on page 4-2
- “Proper Loading” on page 4-2
- “Improper Loading” on page 4-3
- “Maximum Loading” on page 4-3
- “Cycle Counter” on page 4-4

Before a Run

1. Please read and observe the safety instructions contained in these operating instructions and in the instructions for use.
2. Check the rotor and all accessory parts for damages such as cracks, scratches or traces of corrosion.
3. Check the rotor chamber, the motor shaft and the AutoLock™.
4. Check the rotor suitability using the chemical compatibility chart on [page B-1](#).
5. Make sure the tubes or bottles do not touch the bucket caps.
6. Check the rotor bolts and apply grease 7500 3786 before using for the first time.
7. Check that each bucket or microplate carrier can swing freely by moving it carefully with your hand. Weigh the bucket content (adaptor and tube). Make sure you do not exceed the maximum compartment load.



CAUTION Always use identical bucket types in a rotor.
Always be sure to use buckets of the same weight class, which is marked on the buckets themselves.

Proper Loading

To ensure safe operation of the centrifuge, the rotor must be evenly loaded at all times.

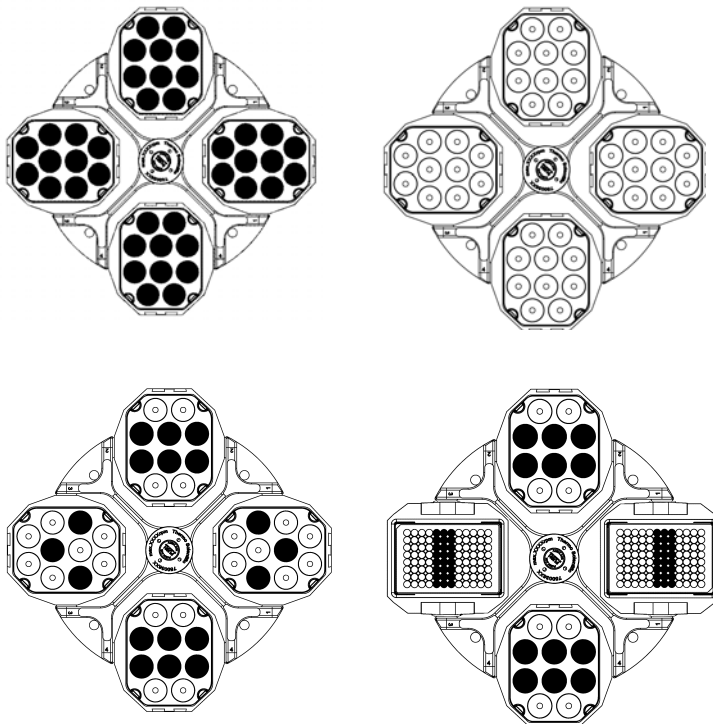

You can use two rectangular buckets or two round buckets or two microplate carriers. Make sure that the opposing receptacles are holding tubes of the same weight.

Improper Loading

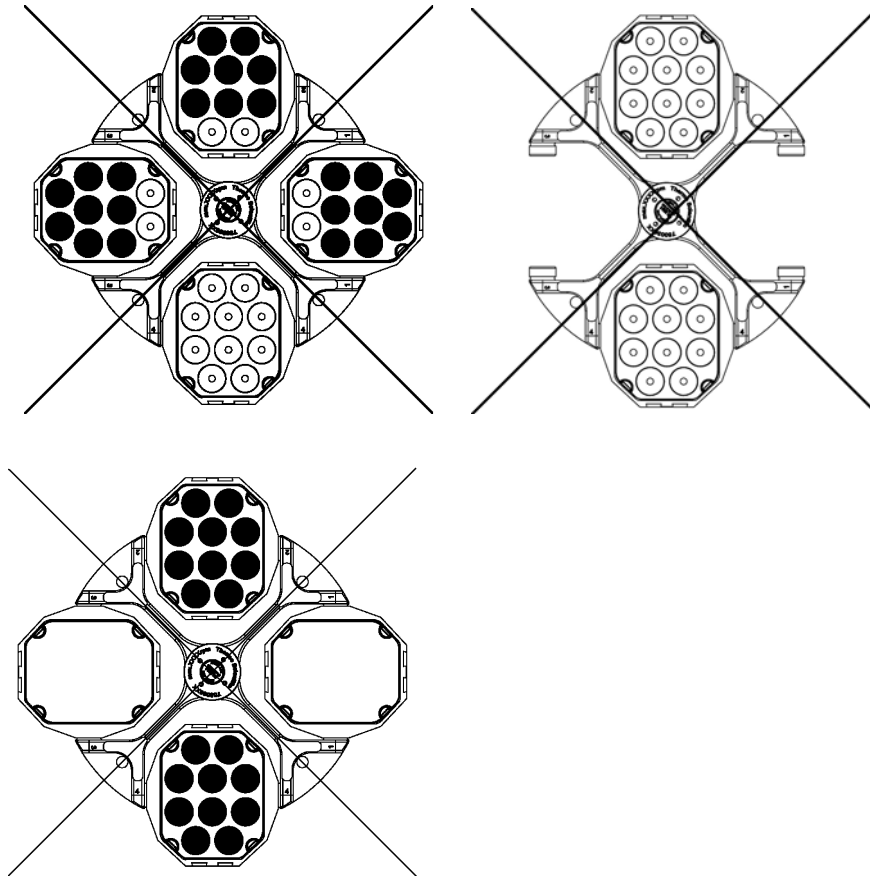

Maximum Loading

The rotor can run at high speeds. The rotor design has sufficient reserve stability even when spinning at top speed.

The safety system of the centrifuge requires that you do not overload the rotor.

There are two options available for centrifuging samples whose weight, including adaptor, exceeds the maximum permissible load:

- Reduce the fill level.

Reduce the speed.

Use the table or the formula:

$$n_{\text{adm}} = n_{\text{max}} \sqrt{\frac{\text{Maximum permissible load}}{\text{Effective load}}}$$

n_{adm} = admissible speed

n_{max} = maximum speed

Round bucket		Rectangular bucket	
Actual Load (g/cavity)	RPM _{max}	Actual Load (g/cavity)	RPM _{max}
800	4700	750	4500
820	4642	770	4441
840	4587	790	4385
860	4533	810	4330
880	4481	830	4278
900	4431	850	4227
920	4383	870	4178
940	4336	890	4131
960	4290	910	4085
980	4246	930	4041
1000	4204	950	3998
1020	4162	970	3957
1040	4122	990	3917
1060	4083	1010	3878
1080	4045	1030	3840
1100	4008	1050	3803

Cycle Counter

The lifetime of rotors and buckets is dependent on the amount of mechanical load. Do not exceed the number of cycles recommended for rotors and buckets.

The maximum number of cycles is given in the rotor table in the rotor specification section.

The maximum number of cycles for buckets is marked on the buckets themselves.



WARNING Replace the rotor when the specified number of cycles is reached. Due to the mechanical load a rotor can break and thus damage the centrifuge. Replace the buckets when the specified number of cycles is reached.

Service life examples

Usage profile	Maximum service life at 50,000 cycles
frequent use 20 runs / day 220 days / year	7 years

Aerosol-tight Applications

Contents

- “Basic Principles” on page 5-2
- “Fill level” on page 5-3
- “Checking the aerosol Tightness” on page 5-2

Basic Principles



CAUTION When centrifuging hazardous samples, do not open aerosol-tight rotors or buckets unless placed in a safety cabinet. Always bear in mind the maximum permitted fill levels.



Be sure to check all seals before starting any aerosol-tight applications.

- Check that the sample containers are well suited for the desired centrifugation process.

Fill Level

The tubes are only to be filled to a level which ensures that the sample is unable to reach the top of the tube during centrifugation. Therefore fill the tube only 2/3 of the rated level.

Checking the aerosol Tightness

The aerosol tightness testing of the rotors and buckets took place according to the microbiological test process in accordance with the EN 61010-2-020 Appendix AA.

Whether or not a rotor is aerosol-tight depends primarily on proper handling.

Check as needed to make sure your rotor is aerosol-tight.

The careful inspection of the seals and seal surfaces for signs of wear and damage such as cracks, scratches and embrittlement is extremely important.

Aerosol-tight applications are not possible if the bucket tops are open.

Aerosol-tightness requires the correct operation when filling the sample vessels and closing the rotor lid.

Quick test

As a quick test, it is possible to test the aerosol-tight beaker and fixed-angle rotors using the following process:

1. Lubricate all seals lightly.
Always use the special grease 7600 3500 when lubricating the seals.
2. Fill the bucket or the rotor with approx. 10 ml of carbonated mineral water.
3. Close the bucket or the rotor as explained in the handling instructions.
4. Shake the bucket or the rotor vigorously using your hands.
This releases the carbonic acid gas which is bound in the water, resulting in excess pressure. Do not apply pressure to the lid when doing so!

Leaks can be detected by escaping water or the sound of escaping gas.

Replace the seals if you detect any leaks. Then repeat the test.

5. Dry the rotor, rotor cover and the cover seal.



CAUTION Prior to each use, the seals in the rotor are to be inspected in order to assure that they are correctly seated and are not worn or damaged. Damaged seals are to be replaced immediately. Replacement seals are supplied with the rotors and can also be re-ordered as a spare parts set. See table in chapter 2. When loading the rotor, ensure that the rotor lid closes securely. Damaged or clouded rotor covers are to be replaced immediately.

Aerosol-tight closure with CLICKSeal

1. If necessary, grease the lid joint before closing the lid. Use grease 76003500 for this.
2. Raise the latch.
The cap can now be easily placed on the bucket.



Figure 5. Bucket with open lid

3. Lower the latch to close the bucket aerosol-tight; be sure the latch clicks into place.



Figure 6. Bucket with closed lid



CAUTION If the latch is not flipped down, the caps could be damaged during centrifuging. If the latch has not clicked into place, the bucket is not aerosol-tight. Never raise the bucket at its latch.

Maintenance and Care

Contents

- “Cleaning Intervals” on page 6-2
- “Cleaning” on page 6-2
- “Disinfection” on page 6-3
- “Decontamination” on page 6-4
- “Autoclaving” on page 6-5
- “Service of Thermo Fisher Scientific” on page 6-6

Cleaning Intervals

For the sake of personal, environmental, and material protection, it is your duty to clean and if necessary disinfect the centrifuge on a regular basis.

Maintenance	Recommended Interval
Clean rotor chamber	daily or when polluted
Clean rotor	daily or when polluted
Accessories	daily or when polluted
Cabinet	Once per month
Ventilation holes	Every six months



CAUTION Refrain from using any other cleaning or decontamination procedure than those recommended here, if you are not entirely sure that the intended procedure is safe for the equipment.
Use only approved cleansers.
If in doubt, contact Thermo Fisher Scientific.

Cleaning

When cleaning centrifug

- Use warm water with a neutral solvent.
- Never use caustic cleaning agents such as soap suds, phosphoric acid, bleaching solutions or scrubbing powder.
- Rinse the cavities out thoroughly.
- Use a soft brush without metal bristles to remove stubborn residue.
- Afterwards rinse with distilled water.
- Place the rotors on a plastic grate with their cavities pointing down.
- If drying boxes are used, the temperature must never exceed 50 °C, since higher temperatures could damage the material and shorten the lifetime of the parts.
- Use only disinfectants with a pH of 6-8.
- Dry aluminum parts off with a soft cloth.
- After cleaning, treat the entire surface of aluminum parts with corrosion protection oil (7000 9824). Also treat the cavities with oil.
- Store the aluminum parts at room temperature or in a cold-storage room with the cavities pointing down.



CAUTION Before using any cleaning or decontamination methods except those recommended by the manufacturer, users should check with the manufacturer that the proposed method will not damage the equipment.

Clean centrifuge and accessories as follows:

1. Open the centrifuge.
2. Turn off the centrifuge.
3. Pull out the power supply plug.
4. Grasp the rotor with both hands and lift it vertically off the centrifuge spindle.
5. Remove the centrifuge tubes and adaptors.
6. Use a neutral cleaning agent with a pH value between 6 and 8 for cleaning.
7. Dry all of the rotors and accessories after cleaning with a cloth or in a warm air cabinet at a maximum temperature of 50°C.
8. Clean the housing of the centrifuge as needed.
 - After cleaning, treat the entire surface of aluminum parts with corrosion protection oil (7000 9824). Also treat the cavities with oil.
 - Tread the bold of the swing out rotor with bold grease (75003786).



CAUTION When cleaning, do not allow liquids, especially organic solvents, to get on the drive shaft, the bearings, the AutoLock™ or the locks. Organic solvents break down the grease in the motor bearing. The drive shaft could freeze up.

After some applications there might be ice in the rotor chamber. Let the ice melt and drain it off. Clean the rotor chamber as described above.

Disinfection

Disinfect the centrifuge immediately whenever infectious material has spilled during centrifugation.



WARNING Infectious material can get into the centrifuge when a tube breaks or as a result of spills. Keep in mind the risk of infection when touching the rotor and take all necessary precautions. In case of contamination, make sure that others are not put at risk. Decontaminate the affected parts immediately. Take other precautions if need be.

Use a sprayer whenever possible so that all surfaces are covered evenly.

The rotor chamber and the rotor should be treated preferably with a neutral disinfectant. A disinfectant spray would be most suitable for this purpose so that the rotor and accessory surfaces are covered evenly.



CAUTION Before using any cleaning or decontamination methods except those recommended by the manufacturer, users should check with the manufacturer that the proposed method will not damage the equipment. Observe the safety precautions and handling instructions for the cleaning agents used.

Contact the Service Department of Thermo Fisher Scientific for questions regarding the use of other disinfectants.

Disinfect the rotor and accessories as follows:

1. Open the centrifuge.
2. Turn off the centrifuge.
3. Pull out the power supply plug.
4. Grasp the rotor with both hands and lift it vertically off the centrifuge spindle.
5. Remove the centrifuge tubes and adaptors and dispose of them or disinfect them.
6. Treat the rotor and accessories according to the instructions for the disinfectant (spray or soak in solution). Adhere strictly to the given application times.
7. Be sure the disinfectant can drain off the rotor.
8. Rinse the rotor and rotor lid thoroughly with water and then rub down.
9. Dispose of the disinfectant according to the applicable guidelines.
10. Dry all of the rotors and accessories after cleaning with a cloth or in a warm air cabinet at a maximum temperature of 50°C.
 - After cleaning, treat the entire surface of aluminum parts with corrosion protection oil (7000 9824). Also treat the cavities with oil.
 - Treat the bolt of the swing out rotor with bolt grease (75003786).

Decontamination

Decantamine the centrifuge immediately whenever radioactive material has spilled during centrifugation.



WARNING Radioactive material can get into the centrifuge when a tube breaks or as a result of spills. Keep in mind the risk of infection when touching the rotor and take all necessary precautions.

In case of contamination, make sure that others are not put at risk.

Decontaminate the affected parts immediately.

Take other precautions if need be.



CAUTION Before using any cleaning or decontamination methods except those recommended by the manufacturer, users should check with the manufacturer that the proposed method will not damage the equipment.

For general radioactive decontamination use a solution of equal parts of 70% ethanol, 10% SDS and water.

Disinfect the rotor and accessories as follows:

1. Open the centrifuge.
2. Turn off the centrifuge.

3. Pull out the power supply plug.
4. Grasp the rotor with both hands and lift it vertically off the centrifuge spindle.
5. Remove the centrifuge tubes and adaptors and dispose of them or disinfect them.
6. Rinse the rotor first with ethanol and then with de-ionized water.
 - Adhere strictly to the given application times.
7. Be sure the decontamination solution can drain off the rotor.
8. Rinse the rotor and accessories thoroughly with water.
9. Dispose of the decontamination solution according to the applicable guidelines.
10. Dry all of the rotors and accessories after cleaning with a cloth or in a warm air cabinet at a maximum temperature of 50°C.
 - After cleaning, treat the entire surface of aluminum parts with corrosion protection oil (7000 9824). Also treat the cavities with oil.
 - Treat the bolt of the swing out rotor with bolt grease (75003786).

Autoclaving

1. Before autoclaving clean rotor and accessories as described above.
2. Place the rotor on a flat surface.
 - Rotors and adapter can be autoclaved at 121 °C.
 - The maximum permissible autoclave cycle is 20 minutes at 121 °C.

Clean the rotor before autoclaving and rinse it with distilled water. Remove all accessories (tubes, adapters) from the rotor. Place the rotor on a flat surface.

Note No chemical additives are permitted in the steam.



CAUTION Never exceed the permitted temperature and duration when autoclaving. If the rotor shows signs of corrosion or wear, it must be replaced.

Service of Thermo Fisher Scientific

Thermo Fisher Scientific recommends having the centrifuge and accessories serviced once a year by an authorized service technician. The service technicians check the following:

- the electrical equipment
- the suitability of the set-up site
- the lid lock and the safety system
- the rotor
- the fixation of the rotor and the drive shaft

Thermo Fisher Scientific offers inspection and service contracts for this work.

RCF-Values

Table A-1.Rectangular buckets 75003614

Speed (rpm)	R _{min}	R _{max}	RCF R _{min}	RCF R _{max}
300	8.9	19.5	9	20
400	8.9	19.5	16	35
500	8.9	19.5	25	55
600	8.9	19.5	36	78
700	8.9	19.5	49	107
800	8.9	19.5	64	140
900	8.9	19.5	81	177
1000	8.9	19.5	100	218
1100	8.9	19.5	120	264
1200	8.9	19.5	143	314
1300	8.9	19.5	168	368
1400	8.9	19.5	195	427
1500	8.9	19.5	224	491
1600	8.9	19.5	255	558
1700	8.9	19.5	288	630
1800	8.9	19.5	322	706
1900	8.9	19.5	359	787
2000	8.9	19.5	398	872
2100	8.9	19.5	439	961
2200	8.9	19.5	482	1055
2300	8.9	19.5	526	1153
2400	8.9	19.5	573	1256
2500	8.9	19.5	622	1363
2600	8.9	19.5	673	1474
2700	8.9	19.5	725	1589
2800	8.9	19.5	780	1709
2900	8.9	19.5	837	1833

Table A-1.Rectangular buckets 75003614

Speed (rpm)	R _{min}	R _{max}	RCF R _{min}	RCF R _{max}
3000	8.9	19.5	896	1962
3100	8.9	19.5	956	2095
3200	8.9	19.5	1019	2232
3300	8.9	19.5	1084	2374
3400	8.9	19.5	1150	2520
3500	8.9	19.5	1219	2671
3600	8.9	19.5	1290	2825
3700	8.9	19.5	1362	2985
3800	8.9	19.5	1437	3148
3900	8.9	19.5	1513	3316
4000	8.9	19.5	1592	3488
4100	8.9	19.5	1673	3665
4200	8.9	19.5	1755	3846
4300	8.9	19.5	1840	4031
4400	8.9	19.5	1926	4221
4500	8.9	19.5	2015	4415

Table A-2.Round bucket 75003608

Speed (rpm)	Min. radius	Max. radius	RCF Rmin	RCF Rmax
300	8.3	19.5	8	20
400	8.3	19.5	15	35
500	8.3	19.5	23	55
600	8.3	19.5	33	78
700	8.3	19.5	45	107
800	8.3	19.5	59	140
900	8.3	19.5	75	177
1000	8.3	19.5	93	218
1100	8.3	19.5	112	264
1200	8.3	19.5	134	314
1300	8.3	19.5	157	368
1400	8.3	19.5	182	427
1500	8.3	19.5	209	491
1600	8.3	19.5	238	558
1700	8.3	19.5	268	630
1800	8.3	19.5	301	706

Table A-2.Round bucket 75003608

Speed (rpm)	Min. radius	Max. radius	RCF Rmin	RCF Rmax
1900	8.3	19.5	335	787
2000	8.3	19.5	371	872
2100	8.3	19.5	409	961
2200	8.3	19.5	449	1055
2300	8.3	19.5	491	1153
2400	8.3	19.5	534	1256
2500	8.3	19.5	580	1363
2600	8.3	19.5	627	1474
2700	8.3	19.5	676	1589
2800	8.3	19.5	728	1709
2900	8.3	19.5	780	1833
3000	8.3	19.5	835	1962
3100	8.3	19.5	892	2095
3200	8.3	19.5	950	2232
3300	8.3	19.5	1011	2374
3400	8.3	19.5	1073	2520
3500	8.3	19.5	1137	2671
3600	8.3	19.5	1203	2825
3700	8.3	19.5	1270	2985
3800	8.3	19.5	1340	3148
3900	8.3	19.5	1411	3316
4000	8.3	19.5	1485	3488
4100	8.3	19.5	1560	3665
4200	8.3	19.5	1637	3846
4300	8.3	19.5	1716	4031
4400	8.3	19.5	1796	4221
4500	8.3	19.5	1879	4415
4600	8.3	19.5	1964	4613
4700	8.3	19.5	2050	4816

Chemical Compatibility Chart

CHEMICAL	MATERIAL																										
	ALUMINUM	ANODIC COATING for ALUMINUM	BUNA N	CELLULOSE ACETATE BUTYRATE	POLYURETHANE ROTOR PAINT	COMPOSITE Carbon Fiber/Epoxy	DELRIN®	ETHYLENE PROPYLENE	GLASS	NEOPRENE	NORYL®	NYLON	PET, POLYCLEAR®, CLEARCRIMP®, CCCLEARCRIMP®	POLYALLOMER	POLYCARBONATE	POLYESTER, GLASS THERMOSET	POLYETHERIMIDE	POLYRTHYLENE	POLYPROPYLENE	POLYSULFONE	POLYVINYL CHLORIDE	RULON A®, TEFLON®	SILICONE RUBBER	STAINLESS STEEL	TITANIUM	TYGON®	VITON®
2-mercaptoethanol	S	S	U	-	S	M	S	-	S	U	S	S	U	S	S	-	S	S	S	S	U	S	S	S	S	S	S
Acetaldehyde	S	-	U	U	-	-	-	M	-	U	-	-	-	M	U	U	U	M	M	-	M	S	U	-	S	-	U
Acetone	M	S	U	U	S	U	M	S	S	U	U	S	U	S	U	U	U	S	S	U	U	S	M	M	S	U	U
Acetonitrile	S	S	U	-	S	M	S	-	S	S	U	S	U	M	U	U	-	S	M	U	U	S	S	S	S	U	U
Alconox®	U	U	S	-	S	S	S	-	S	S	S	S	S	S	M	S	S	S	S	S	S	S	S	S	S	S	U
Allyl Alcohol	-	-	-	U	-	-	S	-	-	-	-	S	-	S	S	M	S	S	S	S	-	M	S	-	-	S	-
Aluminum Chloride	U	U	S	S	S	S	U	S	S	S	S	M	S	S	S	S	-	S	S	S	S	S	M	U	U	S	S
Formic Acid (100%)	-	S	M	U	-	-	U	-	-	-	-	U	-	S	M	U	U	S	S	-	U	S	-	U	S	-	U
Ammonium Acetate	S	S	U	-	S	S	S	-	S	S	S	S	S	S	S	U	-	S	S	S	S	S	S	S	S	S	S
Ammonium Carbonate	M	S	U	S	S	S	S	S	S	S	S	S	S	S	U	U	-	S	S	S	S	S	S	M	S	S	S
Ammonium Hydroxide (10%)	U	U	S	U	S	S	M	S	S	S	S	S	-	S	U	M	S	S	S	S	S	S	S	S	S	S	M
Ammonium Hydroxide (28%)	U	U	S	U	S	U	M	S	S	S	S	S	U	S	U	M	S	S	S	S	S	S	S	S	S	S	M
Ammonium Hydroxide (conc.)	U	U	U	U	S	U	M	S	-	S	-	S	U	S	U	U	S	S	S	-	M	S	S	S	S	-	U
Ammonium Phosphate	U	-	S	-	S	S	S	S	S	S	S	S	-	S	S	M	-	S	S	S	S	S	S	M	S	S	S
Ammonium Sulfate	U	M	S	-	S	S	U	S	S	S	S	S	S	S	S	S	-	S	S	S	S	S	S	U	S	S	U
Amyl Alcohol	S	-	M	U	-	-	S	S	-	M	-	S	-	M	S	S	S	S	M	-	-	-	U	-	S	-	M
Aniline	S	S	U	U	S	U	S	M	S	U	U	U	U	U	U	U	-	S	M	U	U	S	S	S	S	U	S
Sodium Hydroxide (<1%)	U	-	M	S	S	S	-	-	S	M	S	S	-	S	M	M	S	S	S	S	S	S	M	S	S	-	U
Sodium Hydroxide (10%)	U	-	M	U	-	-	U	-	M	M	S	S	U	S	U	U	S	S	S	S	S	S	M	S	S	-	U
Barium Salts	M	U	S	-	S	S	S	S	S	S	S	S	S	S	S	M	-	S	S	S	S	S	M	S	S	S	S
Benzene	S	S	U	U	S	U	M	U	S	U	U	S	U	U	U	M	U	M	U	U	U	S	U	U	S	U	S
Benzyl Alcohol	S	-	U	U	-	-	M	M	-	M	-	S	U	U	U	U	U	U	U	-	M	S	M	-	S	-	S
Boric Acid	U	S	S	M	S	S	U	S	S	S	S	S	S	S	S	S	U	S	S	S	S	S	S	S	S	S	S

B Chemical Compatibility Chart

CHEMICAL	MATERIAL																										
	ALUMINUM	ANODIC COATING for ALUMINUM	BUNA N	CELLULOSE ACETATE BUTYRATE	POLYURETHANE ROTOR PAINT	COMPOSITE Carbon Fiber/Epoxy	DELRIN®	ETHYLENE PROPYLENE	GLASS	NEOPRENE	NORYL®	NYLON	PET®, POLYCLEAR®, CLEARCRIMP®, CCCCLEARCRIMP®	POLYALLUMER	POLYCARBONATE	POLYESTER, GLASS THERMOSET	POLYETHERIMIDE	POLYETHYLENE	POLYPROPYLENE	POLYSULFONE	POLYVINYL CHLORIDE	RULON A®, TEFLON®	SILICONE RUBBER	STAINLESS STEEL	TITANIUM	TYGON®	VITON®
Cesium Acetate	M	-	S	-	S	S	S	-	S	S	S	S	-	S	S	-	-	S	S	S	S	S	S	M	S	S	S
Cesium Bromide	M	S	S	-	S	S	S	-	S	S	S	S	S	S	S	-	-	S	S	S	S	S	S	M	S	S	S
Cesium Chloride	M	S	S	U	S	S	S	-	S	S	S	S	S	S	S	-	-	S	S	S	S	S	S	M	S	S	S
Cesium Formate	M	S	S	-	S	S	S	-	S	S	S	S	S	S	S	-	-	S	S	S	S	S	S	M	S	S	S
Cesium Iodide	M	S	S	-	S	S	S	-	S	S	S	S	S	S	S	-	-	S	S	S	S	S	S	M	S	S	S
Cesium Sulfate	M	S	S	-	S	S	S	-	S	S	S	S	S	S	S	-	-	S	S	S	S	S	S	M	S	S	S
Chloroform	U	U	U	U	S	S	M	U	S	U	U	M	U	M	U	U	U	M	M	U	U	S	U	U	U	M	S
Chromic Acid (10%)	U	-	U	U	S	U	U	-	S	S	S	U	S	S	M	U	M	S	S	U	M	S	M	U	S	S	S
Chromic Acid (50%)	U	-	U	U	-	U	U	-	-	-	S	U	U	S	M	U	M	S	S	U	M	S	-	U	M	-	S
Cresol Mixture	S	S	U	-	-	-	S	-	S	U	U	U	U	U	U	-	-	U	U	-	U	S	S	S	S	U	S
Cyclohexane	S	S	S	-	S	S	S	U	S	U	S	S	U	U	U	M	S	M	U	M	M	S	U	M	M	U	S
Deoxycholate	S	S	S	-	S	S	S	-	S	S	S	S	S	S	S	-	-	S	S	S	S	S	S	S	S	S	S
Distilled Water	S	S	S	S	S	S	S	S	S	S	S	S	S	S	S	S	S	S	S	S	S	S	S	S	S	S	S
Dextran	M	S	S	S	S	S	S	-	S	S	S	S	S	S	S	S	S	S	S	S	S	S	S	M	S	S	S
Diethyl Ether	S	S	U	U	S	S	S	U	S	U	U	S	U	U	U	U	U	U	U	U	U	U	S	S	S	M	U
Diethyl Ketone	S	-	U	U	-	-	M	-	S	U	-	S	-	M	U	U	U	M	M	-	U	S	-	-	S	U	U
Diethylpyrocarbonate	S	S	U	-	S	S	S	-	S	S	U	S	U	S	U	-	-	S	S	S	M	S	S	S	S	S	S
Dimethylsulfoxide	S	S	U	U	S	S	S	-	S	U	S	S	U	S	U	U	-	S	S	U	U	S	S	S	S	U	U
Dioxane	M	S	U	U	S	S	M	M	S	U	U	S	U	M	U	U	-	M	M	M	U	S	S	S	S	U	U
Ferric Chloride	U	U	S	-	-	-	M	S	-	M	-	S	-	S	-	-	-	S	S	-	-	-	M	U	S	-	S
Acetic Acid (Glacial)	S	S	U	U	S	S	U	M	S	U	S	U	U	U	U	U	M	S	U	M	U	S	U	U	S	-	U
Acetic Acid (5%)	S	S	M	S	S	S	M	S	S	S	S	S	M	S	S	S	S	S	S	S	M	S	S	M	S	S	M
Acetic Acid (60%)	S	S	U	U	S	S	U	-	S	M	S	U	U	M	U	S	M	S	M	S	M	S	M	U	S	M	U
Ethyl Acetate	M	M	U	U	S	S	M	M	S	S	U	S	U	M	U	U	-	S	S	U	U	S	M	M	S	U	U
Ethyl Alcohol (50%)	S	S	S	S	S	S	M	S	S	S	S	S	U	S	U	S	S	S	S	S	S	S	S	M	S	M	U
Ethyl Alcohol (95%)	S	S	S	U	S	S	M	S	S	S	S	S	U	S	U	-	S	S	S	M	S	S	S	U	S	M	U
Ethylene Dichloride	S	-	U	U	-	-	S	M	-	U	U	S	U	U	U	U	U	U	U	-	U	S	U	-	S	-	S
Ethylene Glycol	S	S	S	S	S	S	S	S	S	S	S	S	-	S	U	S	S	S	S	S	S	S	S	M	S	M	S
Ethylene Oxide Vapor	S	-	U	-	-	U	-	-	S	U	-	S	-	S	M	-	-	S	S	S	U	S	U	S	S	S	U
Ficoll-Hypaque®	M	S	S	-	S	S	S	-	S	S	S	S	-	S	S	-	S	S	S	S	S	S	S	M	S	S	S

CHEMICAL	MATERIAL	ALUMINUM	ANODIC COATING for ALUMINUM	BUNA N	CELLULOSE ACETATE BUTYRATE	POLYURETHANE ROTOR PAINT	COMPOSITE Carbon Fiber/Epoxy	DELRIN®	ETHYLENE PROPYLENE	GLASS	NEOPRENE	NORYL®	NYLON	PET®, POLYCLEAR®, CLEARCRIMP®, CIRCLECRIMP®	POLYALLUMER	POLYCARBONATE	POLYESTER, GLASS THERMOSET	POLYETHERIMIDE	POLYETHYLENE	POLYPROPYLENE	POLYSULFONE	POLYVINYL CHLORIDE	RULON A®, TEFLON®	SILICONE RUBBER	STAINLESS STEEL	TITANIUM	TYGON®	VITON®
Hydrofluoric Acid (10%)	U	U	U	M	-	-	U	-	-	U	U	S	-	S	M	U	S	S	S	S	M	S	U	U	U	-	-	
Hydrofluoric Acid (50%)	U	U	U	U	-	-	U	-	-	U	U	U	U	S	U	U	U	S	S	M	M	S	U	U	U	-	M	
Hydrochloric Acid (conc.)	U	U	U	U	-	U	U	M	-	U	M	U	U	M	U	U	U	-	S	-	U	S	U	U	U	-	-	
Formaldehyde (40%)	M	M	M	S	S	S	S	M	S	S	S	S	M	S	S	S	U	S	S	M	S	S	S	M	S	M	U	
Glutaraldehyde	S	S	S	S	-	-	S	-	S	S	S	S	S	S	S	-	-	S	S	S	-	-	S	S	S	-	-	
Glycerol	M	S	S	-	S	S	S	S	S	S	S	S	S	S	S	S	-	S	S	S	S	S	S	S	S	S	S	
Guanidine Hydrochloride	U	U	S	-	S	S	S	-	S	S	S	S	S	S	S	-	-	S	S	S	S	S	S	U	S	S	S	
Haemo-Sol®	S	S	S	-	-	-	S	-	S	S	S	S	S	S	S	-	-	S	S	S	S	S	S	S	S	S	S	
Hexane	S	S	S	-	S	S	S	-	S	S	U	S	U	M	U	S	S	U	S	S	M	S	U	S	S	U	S	
Isobutyl Alcohol	-	-	M	U	-	-	S	S	-	U	-	S	U	S	S	M	S	S	S	-	S	S	S	-	S	-	S	
Isopropyl Alcohol	M	M	M	U	S	S	S	S	S	U	S	S	U	S	U	M	S	S	S	S	S	S	S	M	M	M	S	
Iodoacetic Acid	S	S	M	-	S	S	S	-	S	M	S	S	M	S	S	-	M	S	S	S	S	S	M	S	S	M	M	
Potassium Bromide	U	S	S	-	S	S	S	-	S	S	S	S	S	S	S	S	S	S	S	-	S	S	S	M	S	S	S	
Potassium Carbonate	M	U	S	S	S	S	S	-	S	S	S	S	S	S	U	S	S	S	S	S	S	S	S	S	S	S	S	
Potassium Chloride	U	S	S	-	S	S	S	S	S	S	S	S	S	S	S	-	S	S	S	S	S	S	S	U	S	S	S	
Potassium Hydroxide (5%)	U	U	S	S	S	S	M	-	S	S	S	S	-	S	U	S	S	S	S	S	S	S	M	U	M	S	U	
Potassium Hydroxide (conc.)	U	U	M	U	-	-	M	-	M	S	S	-	U	M	U	U	U	S	M	-	M	U	-	U	U	-	U	
Potassium Permanganate	S	S	S	-	S	S	S	-	S	S	S	U	S	S	S	M	-	S	M	S	U	S	S	M	S	U	S	
Calcium Chloride	M	U	S	S	S	S	S	S	S	S	S	S	S	S	M	S	-	S	S	S	S	S	M	S	S	S	S	
Calcium Hypochlorite	M	-	U	-	S	M	M	S	-	M	-	S	-	S	M	S	-	S	S	S	M	S	M	U	S	-	S	
Kerosene	S	S	S	-	S	S	S	U	S	M	U	S	U	M	M	S	-	M	M	M	S	S	U	S	S	U	S	
Sodium Chloride (10%)	S	-	S	S	S	S	S	-	-	-	-	S	S	S	S	S	-	S	S	S	S	-	S	S	M	-	S	
Sodium Chloride (sat'd)	U	-	S	U	S	S	S	-	-	-	-	S	S	S	S	S	-	S	S	-	S	-	S	S	M	-	S	
Carbon Tetrachloride	U	U	M	S	S	U	M	U	S	U	U	S	U	M	U	S	S	M	M	S	M	M	M	M	U	S	S	
Aqua Regia	U	-	U	U	-	-	U	-	-	-	-	-	U	U	U	U	U	U	U	-	-	-	-	-	S	-	M	
Solution 555 (20%)	S	S	S	-	-	-	S	-	S	S	S	S	S	S	S	-	-	S	S	S	-	S	S	S	S	S	S	
Magnesium Chloride	M	S	S	-	S	S	S	S	S	S	S	S	S	S	S	S	S	S	S	S	S	S	S	M	S	S	S	
Mercaptoacetic Acid	U	S	U	-	S	M	S	-	S	M	S	U	U	U	U	-	S	U	U	S	M	S	U	S	S	S	S	
Methyl Alcohol	S	S	S	U	S	S	M	S	S	S	S	S	U	S	U	M	S	S	S	S	S	S	S	M	S	M	U	
Methylene Chloride	U	U	U	U	M	S	S	U	S	U	U	S	U	U	U	U	U	U	M	U	U	U	S	S	M	U	U	

B Chemical Compatibility Chart

CHEMICAL	MATERIAL																										
	ALUMINUM	ANODIC COATING for ALUMINUM	BUNA N	CELLULOSE ACETATE BUTYRATE	POLYURETHANE ROTOR PAINT	COMPOSITE Carbon Fiber/Epoxy	DELRIN®	ETHYLENE PROPYLENE	GLASS	NEOPRENE	NORYL®	NYLON	PET®, POLYCLEAR®, CLEARCRIMP®, CCCCLEARCRIMP®	POLYALLUMER	POLYCARBONATE	POLYESTER, GLASS THERMOSET	POLYETHERIMIDE	POLYETHYLENE	POLYPROPYLENE	POLYSULFONE	POLYVINYL CHLORIDE	RULON A®, TEFLON®	SILICONE RUBBER	STAINLESS STEEL	TITANIUM	TYGON®	VITON®
Methyl Ethyl Ketone	S	S	U	U	S	S	M	S	S	U	U	S	U	S	U	U	U	S	S	U	U	S	S	S	S	U	U
Metrizamide®	M	S	S	-	S	S	S	-	S	S	S	S	-	S	S	-	-	S	S	S	S	S	S	M	S	S	S
Lactic Acid (100%)	-	-	S	-	-	-	-	-	M	S	U	-	S	S	S	M	S	S	-	M	S	M	S	S	-	S	
Lactic Acid (20%)	-	-	S	S	-	-	-	-	M	S	M	-	S	S	S	S	S	S	S	M	S	M	S	S	-	S	
N-Butyl Alcohol	S	-	S	U	-	-	S	-	S	M	-	U	S	M	S	S	S	S	M	M	S	M	-	S	-	S	
N-Butyl Phthalate	S	S	U	-	S	S	S	-	S	U	U	S	U	U	M	-	U	U	S	U	S	M	M	S	U	S	
N, N-Dimethylformamide	S	S	S	U	S	M	S	-	S	S	U	S	U	S	U	-	S	S	U	U	S	M	S	S	S	U	
Sodium Borate	M	S	S	S	S	S	S	S	S	S	S	U	S	S	S	S	-	S	S	S	S	S	M	S	S	S	
Sodium Bromide	U	S	S	-	S	S	S	-	S	S	S	S	S	S	S	S	-	S	S	S	S	S	M	S	S	S	
Sodium Carbonate (2%)	M	U	S	S	S	S	S	S	S	S	S	S	S	U	S	S	S	S	S	S	S	S	S	S	S	S	
Sodium Dodecyl Sulfate	S	S	S	-	S	S	S	-	S	S	S	S	S	S	-	S	S	S	S	S	S	S	S	S	S	S	
Sodium Hypochlorite (5%)	U	U	M	S	S	M	U	S	S	M	S	S	S	M	S	S	S	S	M	S	S	S	M	U	S	M	S
Sodium Iodide	M	S	S	-	S	S	S	-	S	S	S	S	S	S	S	-	-	S	S	S	S	S	M	S	S	S	
Sodium Nitrate	S	S	S	-	S	S	S	S	S	S	S	S	S	S	S	-	S	S	S	S	S	U	S	S	S	S	
Sodium Sulfate	U	S	S	-	S	S	S	S	S	S	S	S	S	S	S	S	S	S	S	S	S	S	M	S	S	S	
Sodium Sulfide	S	-	S	S	-	-	-	S	-	-	-	S	S	S	U	U	-	-	S	-	-	-	S	S	M	-	S
Sodium Sulfite	S	S	S	-	S	S	S	M	S	S	S	S	P	S	S	M	-	S	S	S	S	S	S	S	S	S	
Nickel Salts	U	S	S	S	S	S	-	S	S	S	-	-	S	S	S	-	S	S	S	S	S	S	M	S	S	S	
Oils (Petroleum)	S	S	S	-	-	-	S	U	S	S	S	S	U	U	M	S	M	U	U	S	S	U	S	S	S	S	
Oils (Other)	S	-	S	-	-	-	S	M	S	S	S	S	U	S	S	S	S	U	S	S	S	-	S	S	M	S	
Oleic Acid	S	-	U	S	S	S	U	U	S	U	S	S	M	S	S	S	S	S	S	S	S	M	U	S	M	M	
Oxalic Acid	U	U	M	S	S	S	U	S	S	S	S	U	S	U	S	S	S	S	S	S	S	S	U	M	S	S	
Perchloric Acid (10%)	U	-	U	-	S	U	U	-	S	M	M	-	-	M	U	M	S	M	M	-	M	S	U	-	S	-	S
Perchloric Acid (70%)	U	U	U	-	-	U	U	-	S	U	M	U	U	M	U	U	M	M	U	M	S	U	U	S	U	S	
Phenol (5%)	U	S	U	-	S	M	M	-	S	U	M	U	U	S	U	M	S	M	S	U	U	S	U	M	M	M	S
Phenol (50%)	U	S	U	-	S	U	M	-	S	U	M	U	U	U	U	S	U	M	U	U	S	U	U	U	M	S	
Phosphoric Acid (10%)	U	U	M	S	S	S	U	S	S	S	S	U	-	S	S	S	S	S	S	S	S	U	M	U	S	S	
Phosphoric Acid (conc.)	U	U	M	M	-	-	U	S	-	M	S	U	U	M	M	S	S	M	S	M	S	U	M	U	-	S	
Physiologic Media (Serum, Urine)	M	S	S	S	-	-	S	-	S	S	S	S	S	S	S	S	S	S	S	S	S	S	S	S	S	S	S
Picric Acid	S	S	U	-	S	M	S	S	S	M	S	U	S	S	S	U	S	S	S	S	U	S	U	M	S	M	S

CHEMICAL	MATERIAL																										
	ALUMINUM	ANODIC COATING for ALUMINUM	BUNA N	CELLULOSE ACETATE BUTYRATE	POLYURETHANE ROTOR PAINT	COMPOSITE Carbon Fiber/Epoxy	DELRIN®	ETHYLENE PROPYLENE	GLASS	NEOPRENE	NORYL®	NYLON	PET®, POLYCLEAR®, CLEARCRIMP®, CIRCLECRIMP®	POLYALLUMER	POLYCARBONATE	POLYESTER, GLASS THERMOSET	POLYETHERIMIDE	POLYETHYLENE	POLYPROPYLENE	POLYSULFONE	POLYVINYL CHLORIDE	RULON A®, TEFLON®	SILICONE RUBBER	STAINLESS STEEL	TITANIUM	TYGON®	VITON®
Pyridine (50%)	U	S	U	U	S	U	U	-	U	S	S	U	U	M	U	U	-	U	S	M	U	S	S	U	U	U	U
Rubidium Bromide	M	S	S	-	S	S	S	-	S	S	S	S	S	S	S	-	-	S	S	S	S	S	S	M	S	S	S
Rubidium Chloride	M	S	S	-	S	S	S	-	S	S	S	S	S	S	S	-	-	S	S	S	S	S	S	M	S	S	S
Sucrose	M	S	S	-	S	S	S	S	S	S	S	S	S	S	S	S	S	S	S	S	S	S	S	S	S	S	S
Sucrose, Alkaline	M	S	S	-	S	S	S	-	S	S	S	S	S	S	U	S	S	S	S	S	S	S	S	M	S	S	S
Sulfosalicylic Acid	U	U	S	S	S	S	S	-	S	S	S	U	S	S	S	-	S	S	S	-	S	S	S	U	S	S	S
Nitric Acid (10%)	U	S	U	S	S	U	U	-	S	U	S	U	-	S	S	S	S	S	S	S	S	S	M	S	S	S	S
Nitric Acid (50%)	U	S	U	M	S	U	U	-	S	U	S	U	U	M	M	U	M	M	M	S	S	S	U	S	S	M	S
Nitric Acid (95%)	U	-	U	U	-	U	U	-	-	U	U	U	U	M	U	U	U	U	M	U	U	S	U	S	S	-	S
Hydrochloric Acid (10%)	U	U	M	S	S	S	U	-	S	S	S	U	U	S	U	S	S	S	S	S	S	S	S	U	M	S	S
Hydrochloric Acid (50%)	U	U	U	U	S	U	U	-	S	M	S	U	U	M	U	U	S	S	S	S	M	S	M	U	U	M	M
Sulfuric Acid (10%)	M	U	U	S	S	U	U	-	S	S	M	U	S	S	S	S	S	S	S	S	S	S	U	U	U	S	S
Sulfuric Acid (50%)	M	U	U	U	S	U	U	-	S	S	M	U	U	S	U	U	M	S	S	S	S	S	U	U	U	M	S
Sulfuric Acid (conc.)	M	U	U	U	-	U	U	M	-	-	M	U	U	S	U	U	U	M	S	U	M	S	U	U	U	-	S
Stearic Acid	S	-	S	-	-	-	S	M	S	S	S	S	-	S	S	S	S	S	S	S	S	S	M	M	S	S	S
Tetrahydrofuran	S	S	U	U	S	U	U	M	S	U	U	S	U	U	U	-	M	U	U	U	U	S	U	S	S	U	U
Toluene	S	S	U	U	S	S	M	U	S	U	U	S	U	U	U	S	U	M	U	U	U	S	U	S	U	U	M
Trichloroacetic Acid	U	U	U	-	S	S	U	M	S	U	S	U	U	S	M	-	M	S	S	U	U	S	U	U	U	M	U
Trichloroethane	S	-	U	-	-	-	M	U	-	U	-	S	U	U	U	U	U	U	U	U	U	S	U	-	S	-	S
Trichloroethylene	-	-	U	U	-	-	-	U	-	U	-	S	U	U	U	U	U	U	U	U	U	S	U	-	U	-	S
Trisodium Phosphate	-	-	-	S	-	-	M	-	-	-	-	-	-	S	-	-	S	S	S	-	-	S	-	-	S	-	S
Tris Buffer (neutral pH)	U	S	S	S	S	S	S	-	S	S	S	S	S	S	S	S	S	S	S	S	S	S	S	S	S	S	S
Triton X-100®	S	S	S	-	S	S	S	-	S	S	S	S	S	S	S	S	S	S	S	S	S	S	S	S	S	S	S
Urea	S	-	U	S	S	S	S	-	-	-	-	S	S	S	M	S	S	S	S	-	S	S	S	M	S	-	S
Hydrogen Peroxide (10%)	U	U	M	S	S	U	U	-	S	S	S	U	S	S	S	M	U	S	S	S	S	S	S	M	S	U	S
Hydrogen Peroxide (3%)	S	M	S	S	S	-	S	-	S	S	S	S	S	S	S	S	M	S	S	S	S	S	S	S	S	S	S
Xylene	S	S	U	S	S	S	M	U	S	U	U	U	U	U	U	M	U	M	U	U	U	S	U	M	S	U	S
Zinc Chloride	U	U	S	S	S	S	U	S	S	S	S	S	S	S	S	S	S	S	S	S	S	S	S	S	S	S	S
Zinc Sulfate	U	S	S	-	S	S	S	S	S	S	S	S	S	S	S	S	S	S	S	S	S	S	S	S	S	S	S
Citric Acid (10%)	M	S	S	M	S	S	M	S	S	S	S	S	S	S	S	S	M	S	S	S	S	S	S	S	S	S	S

B Chemical Compatibility Chart

*Polyethyleneterephthalate

Key

S Satisfactory

M = Moderate attack, may be satisfactory for use in centrifuge depending on length of exposure, speed involved, etc.; suggest testing under actual conditions of use.

U Unsatisfactory, not recommended.

-- Performance unknown; suggest testing, using sample to avoid loss of valuable material.

Chemical resistance data is included only as a guide to product use. Because no organized chemical resistance data exists for materials under the stress of centrifugation, when in doubt we recommend pretesting sample lots.

Contact Information

United States	866-9-THERMO
	+1 866 984 3766

Canada	+1 866 984 3766
--------	-----------------

Austria	+43 1 801 400
---------	---------------

Belgium	+32 2 482 30 30
---------	-----------------

Germany	08001 536 376
	+49 6184 90 6940

France	+33 2 2803 2180
	+33 2 2803 2000

Italy	+39 02 02 95059 341
-------	---------------------

Netherlands	+31 76 571 4440
-------------	-----------------

Nordic / Baltic Countries	+35 89 329 100
---------------------------	----------------

Russia	+7 (812) 703 42 15
--------	--------------------

C Contact Information

Spain +34 932 23 09 18

Portugal +34 932 23 09 18

Switzerland +41 44 454 12 12

UK / Ireland +44 870 609 9203

China +86 21 6865 4588

+86 10 8419 3588

India +91 22 6716 2200

Japan +81 45 453 9220

Other Asian Countries +852 2885 4613

Latin America +1 866 984 3766

Other Countries +49 6184 90 6940

+33 2 2803 2180

Index

A	
Accessories	2-1
Aerosol-tight Applications	5-1
Autoclaving	6-5
AutoLock™	3-1
B	
Basic Principles	5-2
Before a Run	4-2
C	
Care	6-1
Checking the aerosol Tightness	5-2
Chemical Compatibility Chart	B-1
Cleaning	6-2
Cleaning Intervals	6-2
CLICKSeal	5-3
Contact Information	D-1
Cycle Counter	4-5
D	
Decontamination	6-4
Disinfection	6-3
F	
Fill Level	5-2
H	
Heraeus	1-2
I	
Improper Loading	4-3
M	
Maintenance	6-1
Maximum Loading	4-4
P	
Precautions	iii
Preface	iii
Proper Loading	4-2
R	
RCF-Values	A-1
Removing the Rotor	3-3
Rotor Installation	3-2
Rotor Loading	4-1
Rotor Specifications	1-1
S	
Scope of Supply	iii
Service	6-6
Service Life	C-1
Sorvall	1-6
T	
Thermo Scientific	1-12
W	
Warranty	C-1

